

Department of Mechanical Engineering

Finite Element Analysis

Introduction to Finite Elements

EXT SMOOTHED
EFFECTIVE
STRESS
RST CALC
TIME = .000

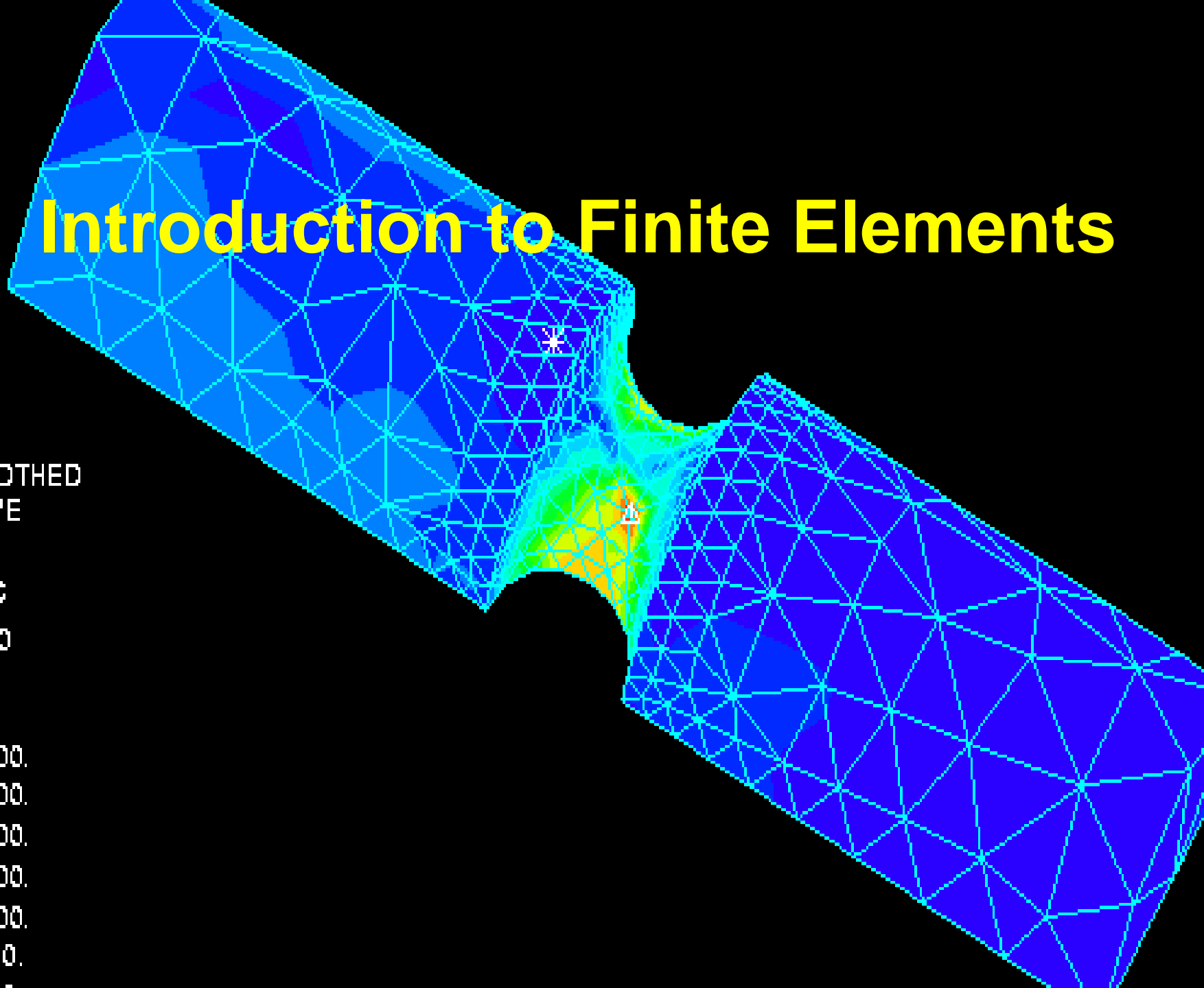

DEFINITION

- Finite Element Analysis (FEA) is a numerical method based on the idea of dividing a complicated object into small manageable pieces.

Numerical method

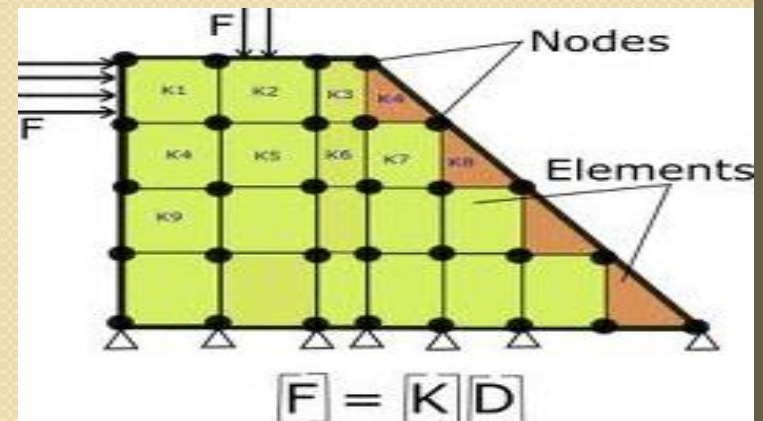

The study of approximation techniques for solving mathematical problems, taking into account the extent of possible errors

Finite Element Analysis

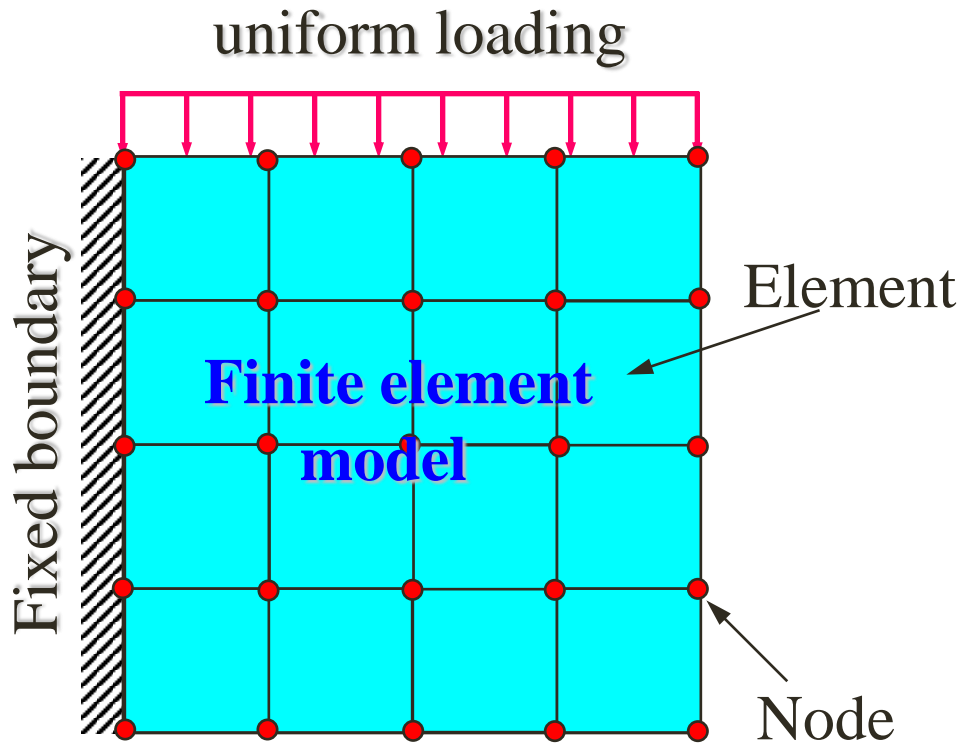

- Approximate method
- Geometric model
- Node
- Element
- Mesh
- Discretization

Problem: Obtain the stresses/strains in the plate

Introduction to Finite Element Method

Mathematic Model

Finite Element Method

Historical Background

Analytical Process of FEM

Applications of FEM

Computer Programs for FEM

What is the Finite Element Method– An Example

Example 1: Deformation of a bar with a non-uniform circular cross section subject a force P . (Weight of the bar is negligible).

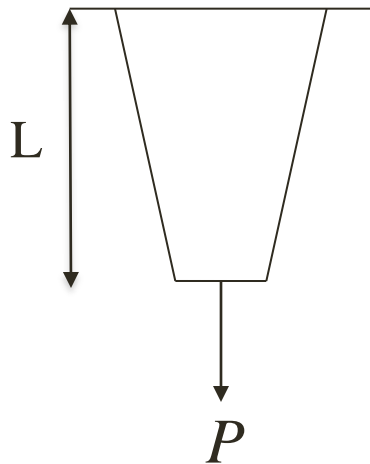

$$\begin{aligned}
 R - k_1(u_2 - u_1) &= 0 \\
 k_1(u_2 - u_1) - k_2(u_3 - u_2) &= 0 \\
 k_2(u_3 - u_2) - k_3(u_4 - u_3) &= 0 \\
 k_3(u_4 - u_3) - k_4(u_5 - u_4) &= 0 \\
 k_4(u_5 - u_4) - P &= 0
 \end{aligned}
 \Rightarrow
 \begin{bmatrix}
 k_1 & -k_1 & 0 & 0 & 0 & 0 \\
 -k_1 & k_1 + k_2 & -k_2 & 0 & 0 & 0 \\
 0 & -k_2 & k_2 + k_3 & -k_3 & 0 & 0 \\
 0 & 0 & -k_3 & k_3 + k_4 & -k_4 & 0 \\
 0 & 0 & 0 & -k_4 & k_4 + k_5 & -k_5 \\
 0 & 0 & 0 & 0 & -k_5 & k_5
 \end{bmatrix}
 \begin{Bmatrix}
 u_1 \\
 u_2 \\
 u_3 \\
 u_4 \\
 u_5 \\
 u_6
 \end{Bmatrix}
 =
 \begin{Bmatrix}
 -R \\
 0 \\
 0 \\
 0 \\
 0 \\
 P
 \end{Bmatrix}
 \Rightarrow [\mathbf{K}]\{\mathbf{u}\} = \{\mathbf{P}\} - \{\mathbf{R}\}$$

What is a Finite Element Method

- View the problem domain as a collection of subdomains (elements)
- Solve the problem at each subdomain
- Assemble elements to find the global solution
- Solution is guaranteed to converge to the correct solution if proper theory, element formulation and solution procedure are followed.

History of Finite Element Methods

- 1941 – Hrenikoff proposed framework method
- 1943 – Courant used principle of stationary potential energy and piecewise function approximation
- 1953 – Stiffness equations were written and solved using digital computers.
- 1960 – Clough made up the name “finite element method”
- 1970s – FEA carried on “mainframe” computers
- 1980s – FEM code run on PCs
- 2000s – Parallel implementation of FEM (large-scale analysis, virtual design)

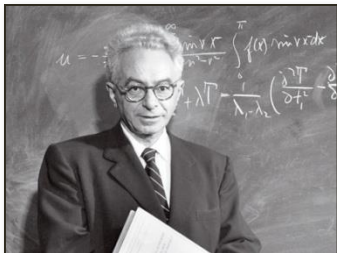

Courant



Clough

Applications of Finite Element Methods

- *Structural & Stress Analysis*
- *Thermal Analysis*
- *Dynamic Analysis*
- *Acoustic Analysis*
- *Electro-Magnetic Analysis*
- *Manufacturing Processes*
- *Fluid Dynamics*
- *Financial Analysis*

Applications: Aerospace Engineering (AE)

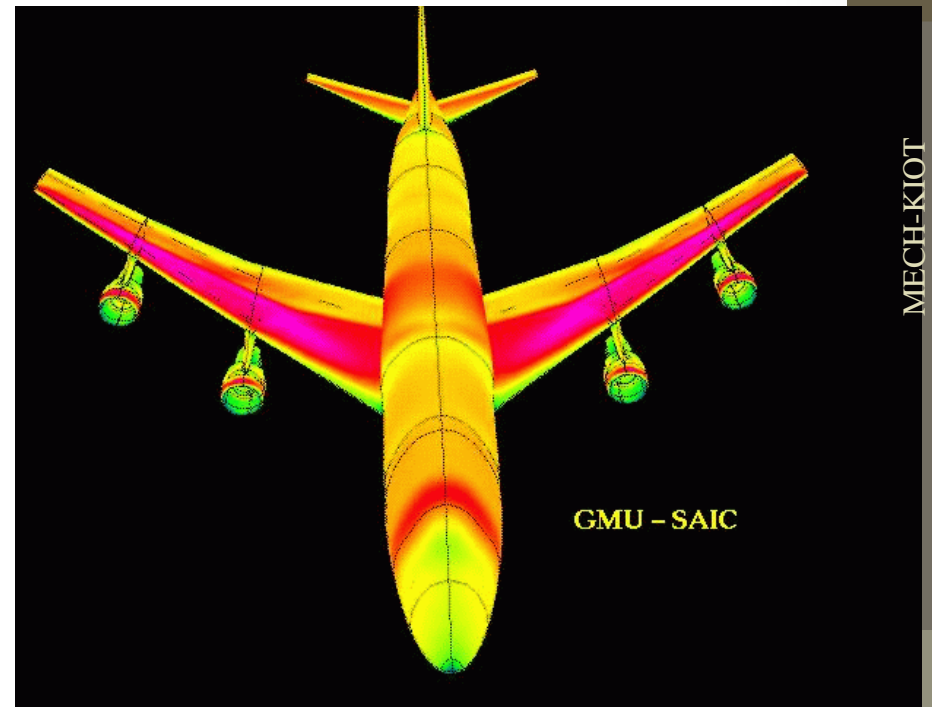
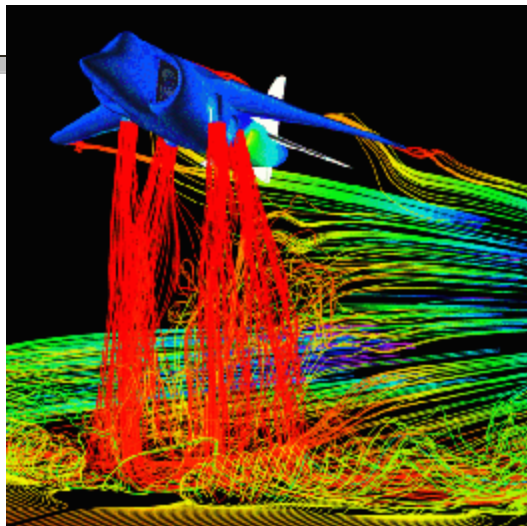
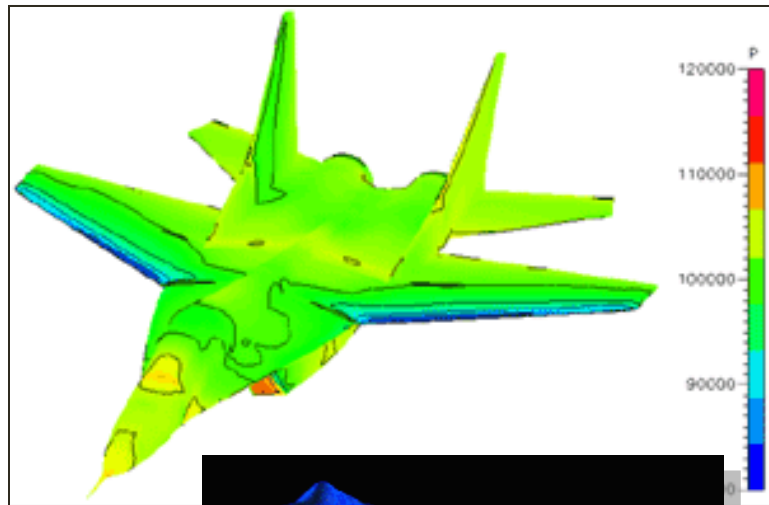

Applications: Civil Engineering (CE)

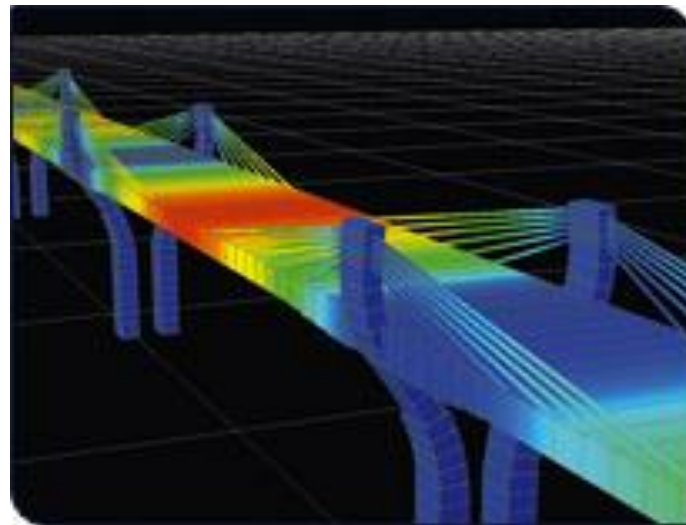
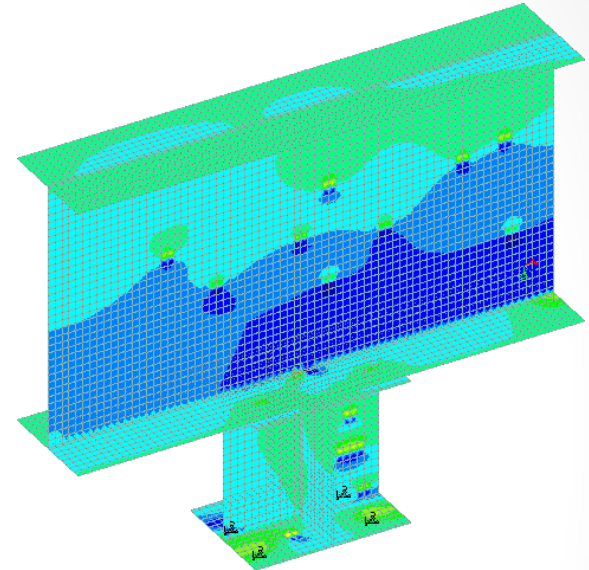

Applications: Electrical Engineering (EE)

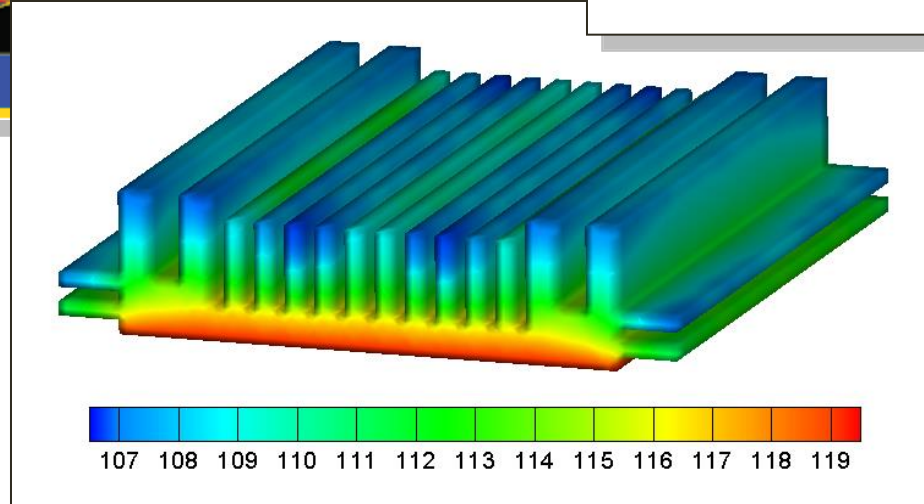
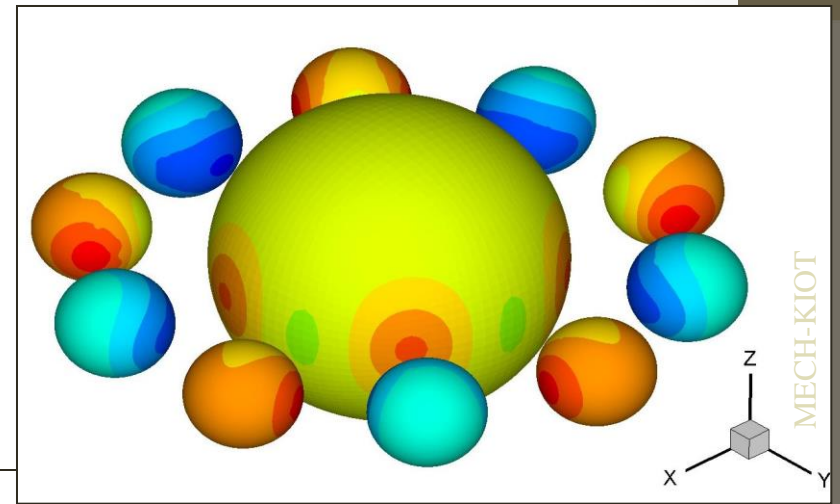
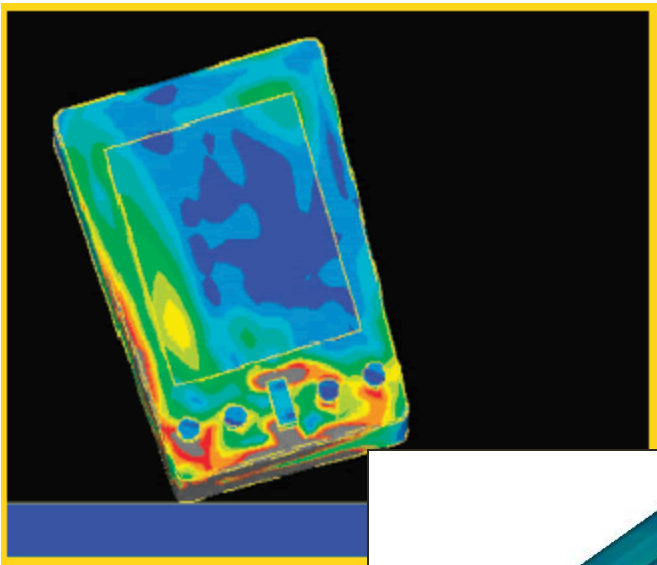

Applications: Biomedical Engineering (BE)

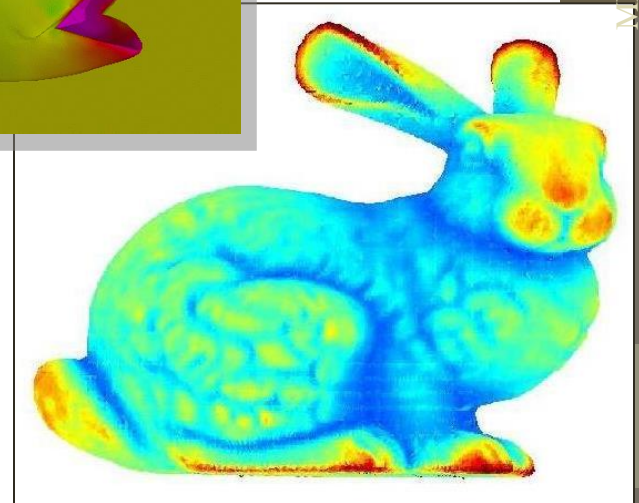
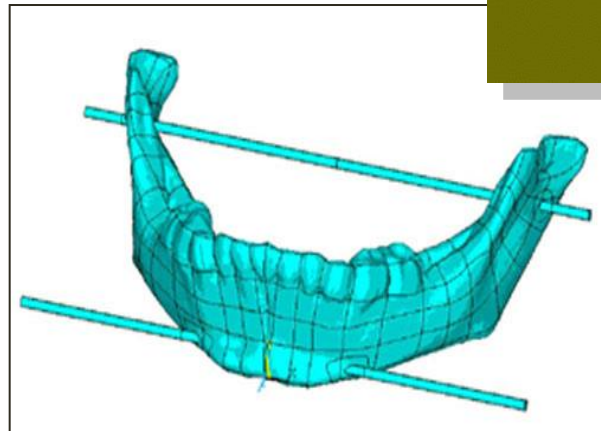
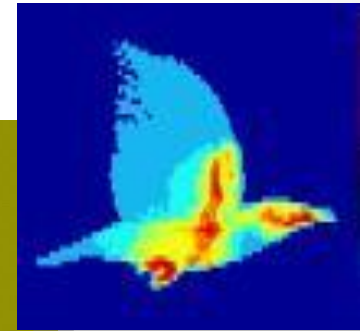
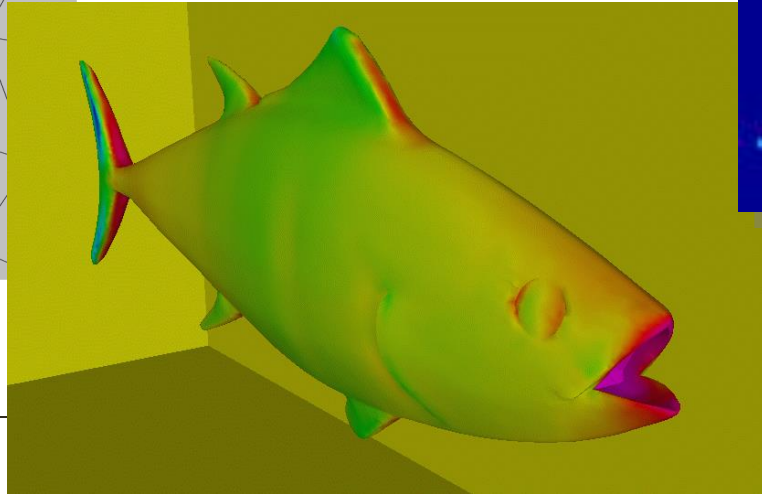
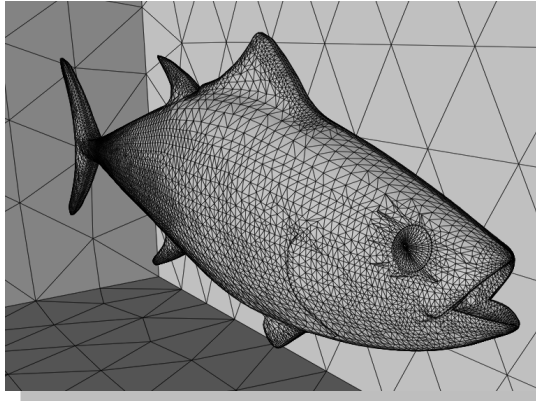

The Future – Virtual Engineering



Review of Basic Statics and Mechanics of Materials

- Static equilibrium conditions/free-body diagram
- Stress, strain and deformation
- Constitutive law – Hooke's law
- Analysis of axially loaded bar, truss, beam and frame
- 2-D elasticity

Review of Matrix Algebra

- Matrix operation: addition, subtraction, multiplication
- Basic definitions and properties of matrix
- Inverse of matrix and solution of linear equations
- etc

1. Mathematical Model

(1) Modeling

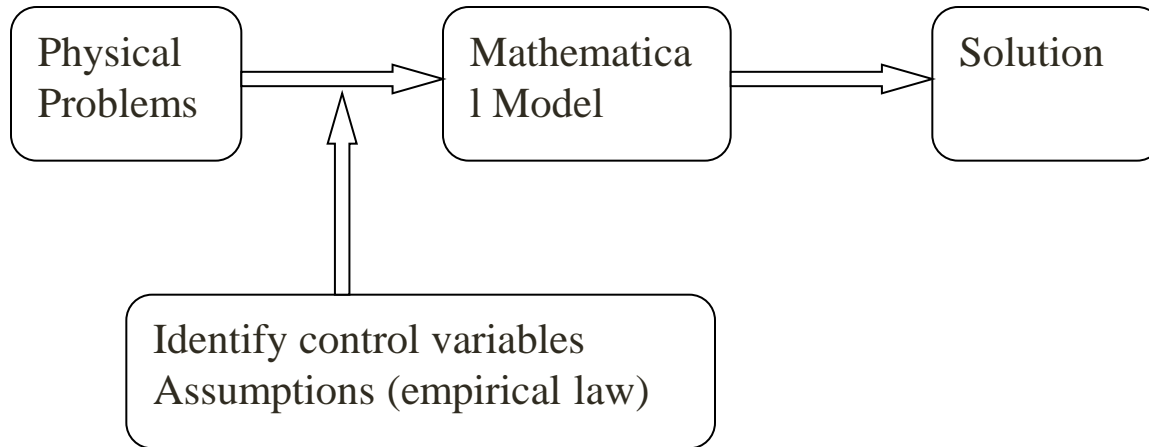

(2) Types of solution

Sol. \ Eq.	Exact Eq.	Approx. Eq.
Exact Sol.	⊙	⊙
Approx. Sol.	⊙	⊙

(3) Methods of Solution

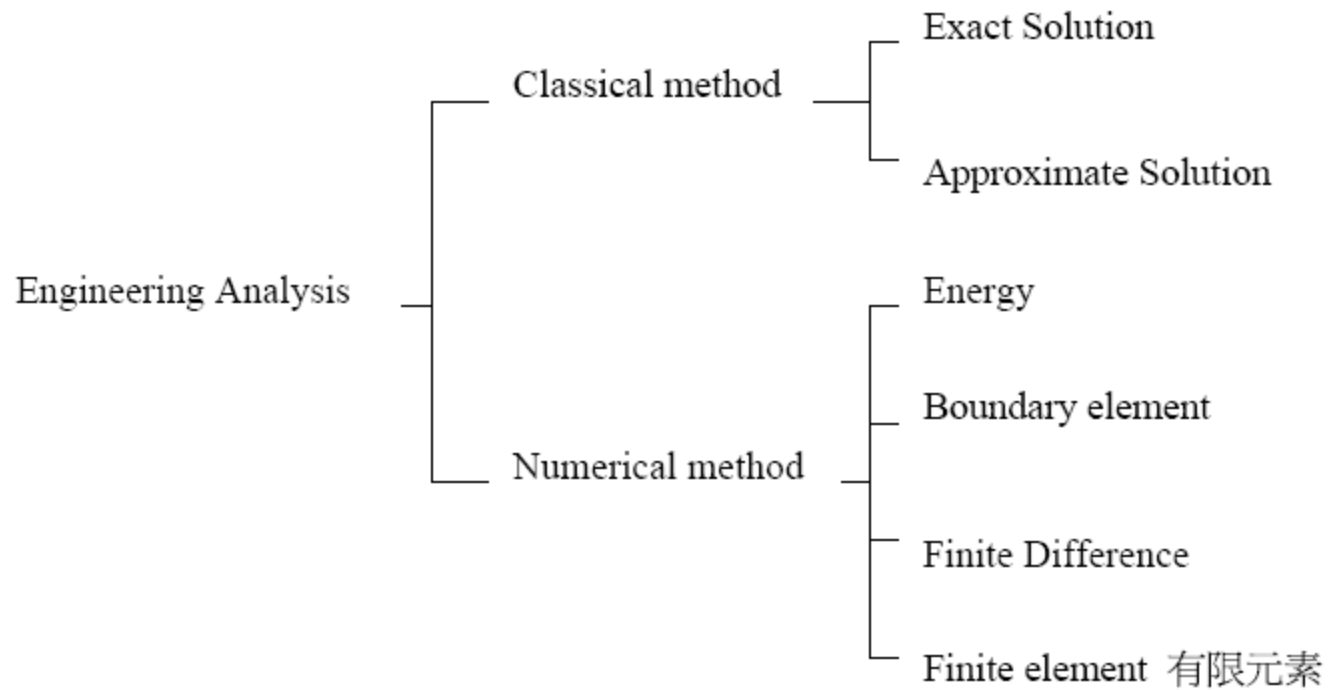

(3) Method of Solution

A. Classical methods

They offer a high degree of insight, but the problems are difficult or impossible to solve for anything but simple geometries and loadings.

B. Numerical methods

(I) Energy: Minimize an expression for the potential energy of the structure over the whole domain.

(II) Boundary element: Approximates functions satisfying the governing differential equations not the boundary conditions.

(III) Finite difference: Replaces governing differential equations and boundary conditions with algebraic finite difference equations.

(IV) Finite element: Approximates the behavior of an irregular, continuous structure under general loadings and constraints with an assembly of discrete elements.

2. Finite Element Method

(1) Definition

FEM is a numerical method for solving a system of governing equations over the domain of a continuous physical system, which is discretized into simple geometric shapes called finite element.

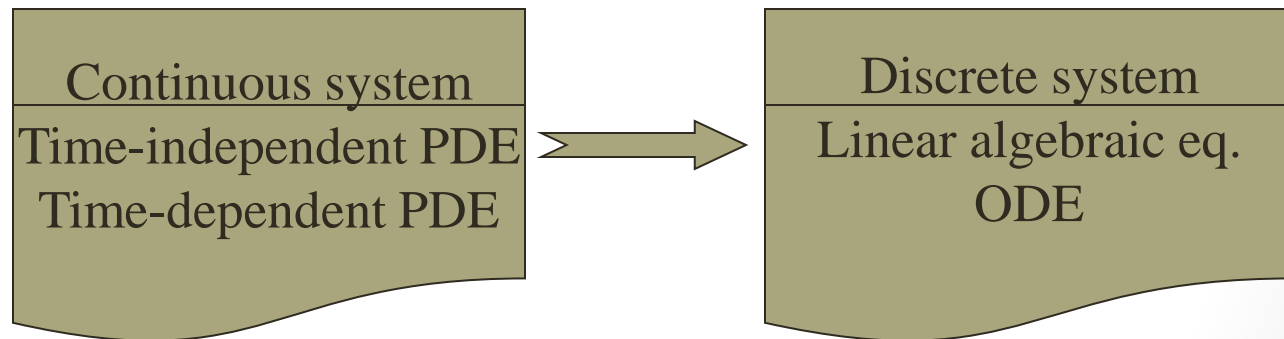

(2) Discretization

Modeling a body by dividing it into an equivalent system of finite elements interconnected at a finite number of points on each element called nodes.

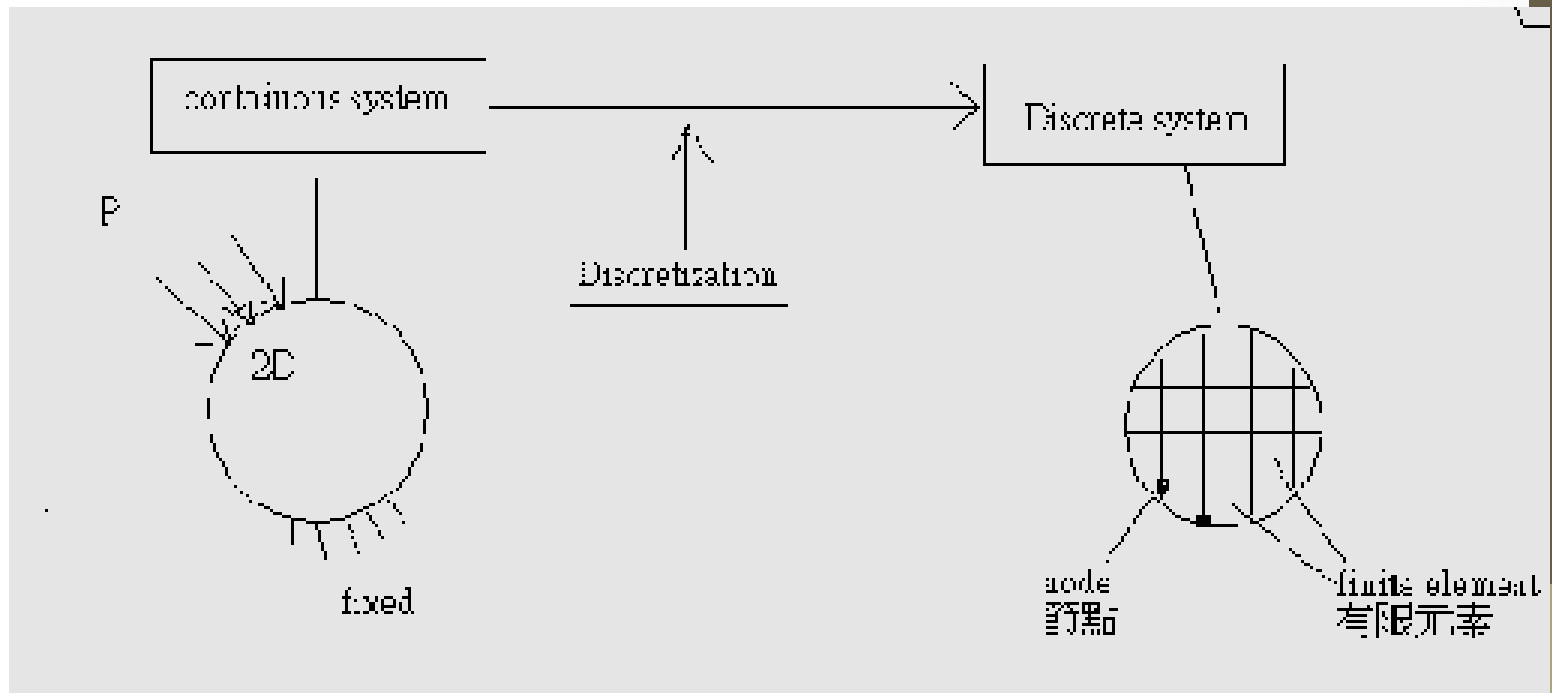

3. Historical Background

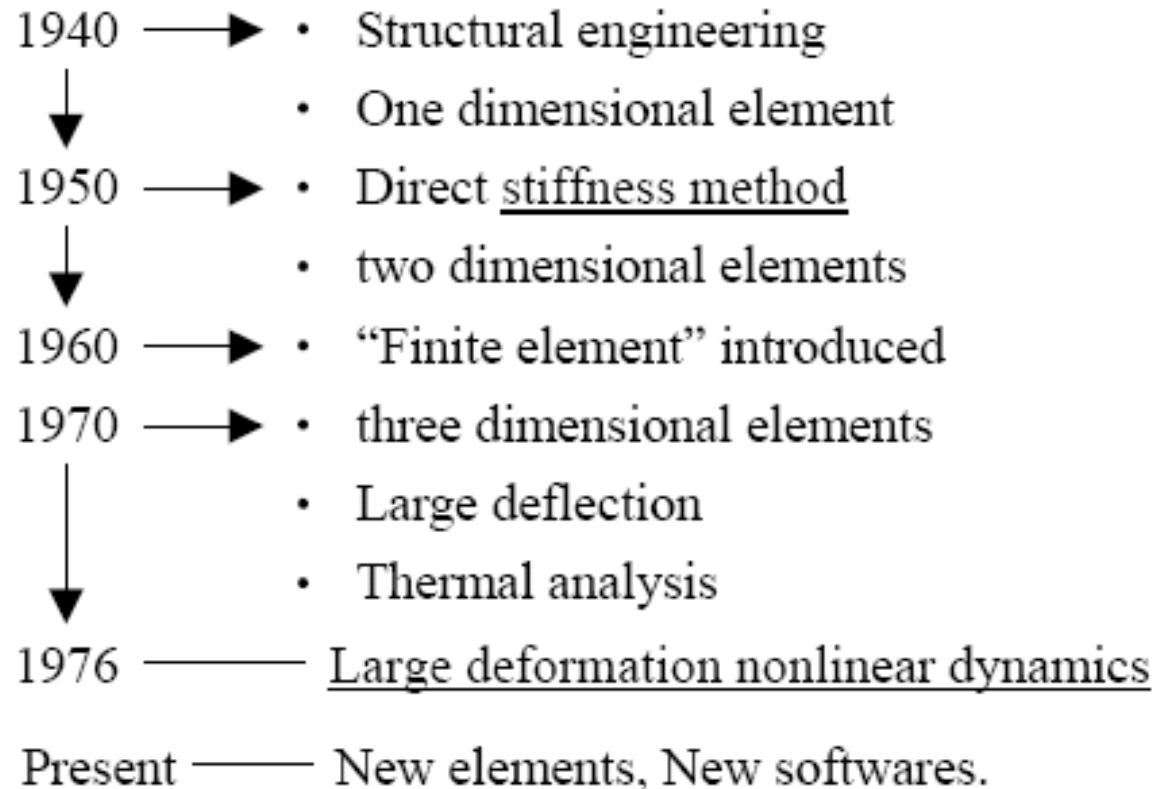

Chronicle of Finite Element Method

Year	Scholar	Theory
1941	Hrennikoff	Presented a solution of elasticity problem using one-dimensional elements.
1943	McHenry	Same as above.
1943	Courant	Introduced shape functions over triangular subregions to model the whole region.
1947	Levy	Developed the force (flexibility) method for structure problem.
1953	Levy	Developed the displacement (stiffness) method for structure problem.
1954	Argyris & Kelsey	Developed matrix structural analysis methods using energy principles.
1956	Turner, Clough, Martin, Topp	Derived stiffness matrices for truss, beam and 2D plane stress elements. Direct stiffness method.
1960	Clough	Introduced the phrase finite element .
1960	Turner et. al	Large deflection and thermal analysis.
1961	Melosh	Developed plate bending element stiffness matrix.
1961	Martin	Developed the tetrahedral stiffness matrix for 3D problems.
1962	Gallagher et al	Material nonlinearity.

Chronicle of Finite Element Method

Year	Scholar	Theory
1963	Grafton, Strome	Developed curved-shell bending element stiffness matrix.
1963	Melosh	Applied variational formulation to solve nonstructural problems.
1965	Clough et. al	3D elements of axisymmetric solids.
1967	Zienkiewicz et.	Published the first book on finite element.
1968	Zienkiewicz et.	Visco-elasticity problems.
1969	Szabo & Lee	Adapted weighted residual methods in structural analysis.
1972	Oden	Book on nonlinear continua.
1976	Belytschko	Large-displacement nonlinear dynamic behavior.
~1997		New element development, convergence studies, the developments of supercomputers, the availability of powerful microcomputers, the development of user-friendly general-purpose finite element software packages.

4. Analytical Processes of Finite Element Method

(1) Structural stress analysis problem

- A. Conditions that solution must satisfy
 - a. Equilibrium
 - b. Compatibility
 - c. Constitutive law
 - d. Boundary conditions

Above conditions are used to generate a system of equations representing system behavior.

B. Approach

- a. Force (flexibility) method: internal forces as unknowns.
- b. Displacement (stiffness) method: nodal disp. As unknowns.

For computational purpose, the displacement method is more desirable because its formulation is simple. A vast majority of general purpose FE softwares have incorporated the displacement method for solving structural problems.

(2) Analysis procedures of linear static structural analysis

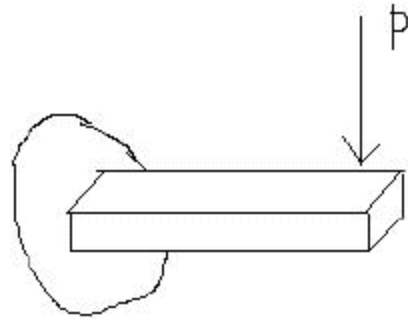

{ 1D problem ?
2D problem ?
3D problem ?

A. Build up geometric model

a. 1D problem

line 

b. 2D problem

surface 

c. 3D problem

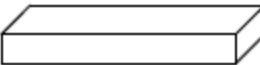
solid 

B. Construct the finite element model

a. Discretize and select the element types

(a) element type

1D line element



2D element



3D brick element

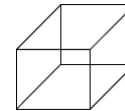

(b) total number of element (mesh)

1D:



2D:

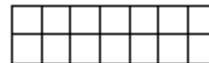

3D:

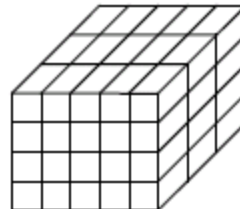

C. Solve the system equations

a. elimination method

Gauss's method (Nastran)

b. iteration method

Gauss Seidel's method

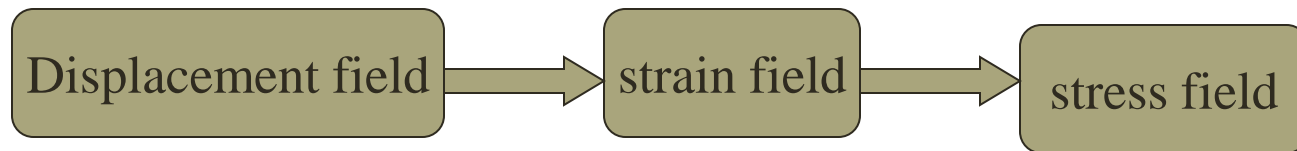

D. Interpret the results (postprocessing)

a. deformation plot



b. stress contour

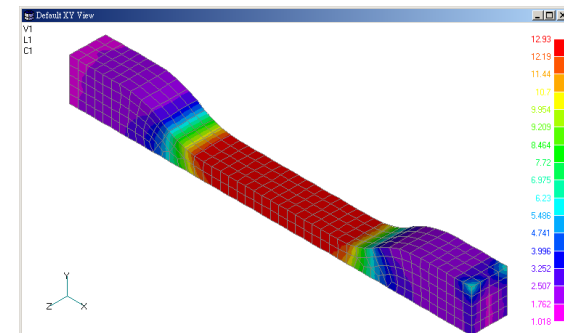

5. Applications of Finite Element Method

Structural Problem	Non-structural Problem
Stress Analysis - truss & frame analysis - stress concentrated problem Buckling problem Vibration Analysis Impact Problem	Heat Transfer Fluid Mechanics Electric or Magnetic Potential

What is a matrix?

A rectangular array of numbers (we will concentrate on real numbers). A $n \times m$ matrix has 'n' rows and 'm' columns

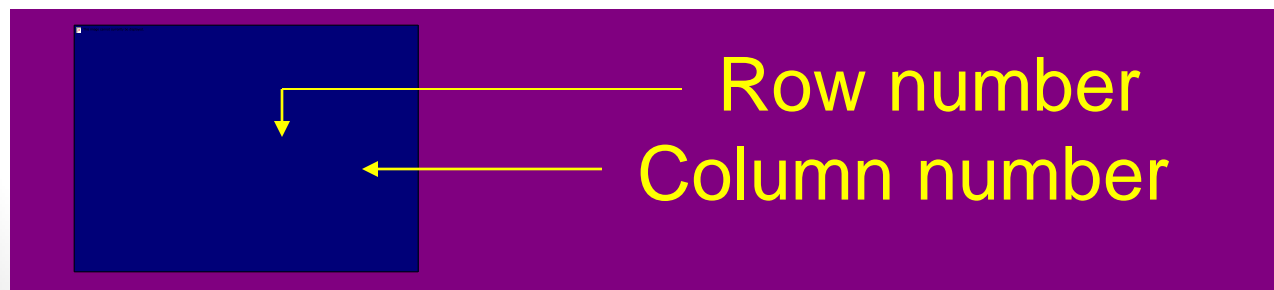
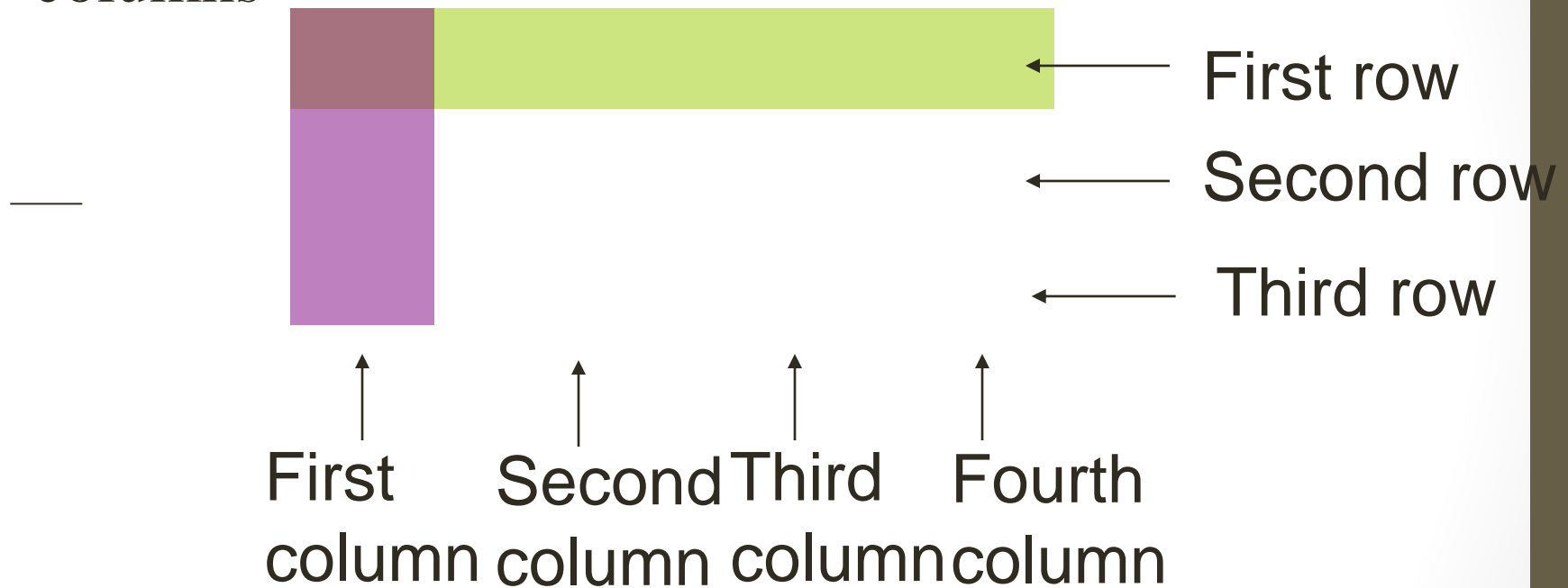

What is a vector?

A vector is an array of 'n' numbers

A row vector of length 'n' is a $1 \times n$ matrix

A column vector of length 'm' is a $m \times 1$ matrix



Special matrices

Zero matrix: A matrix all of whose entries are zero

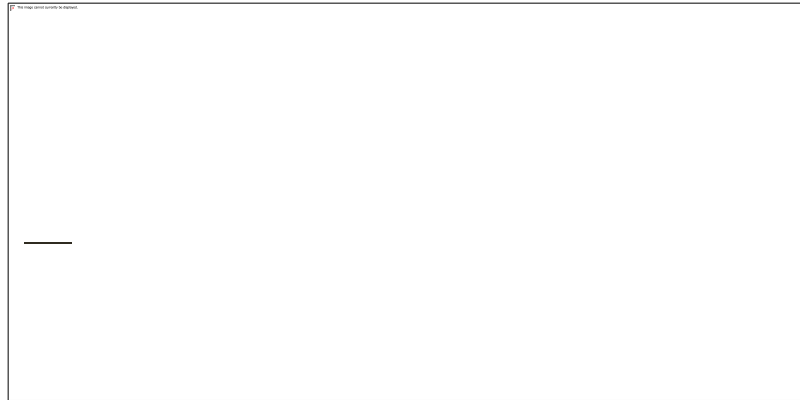

Identity matrix: A square matrix which has '1's on the diagonal and zeros everywhere else.

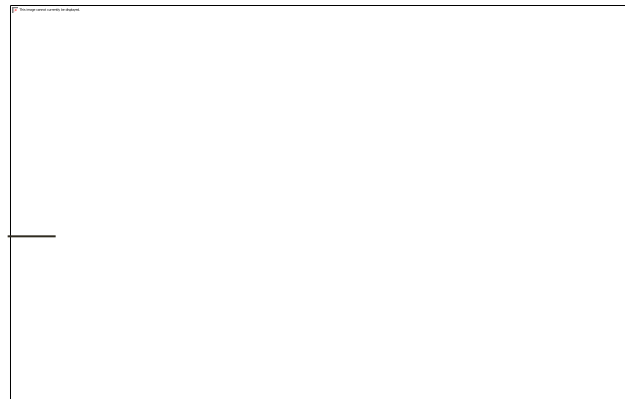

What is a cofactor?

Sign of cofactor

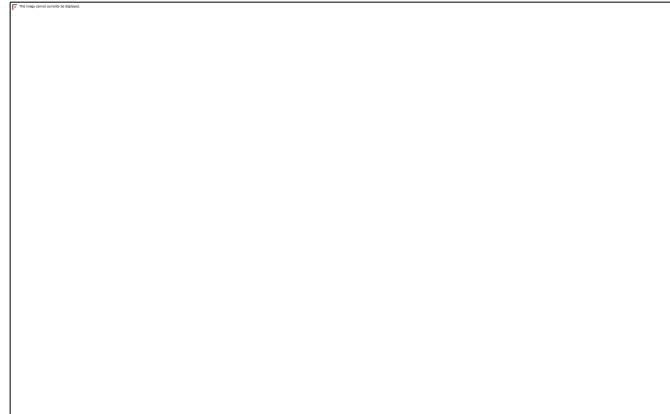

Find the minor and cofactor of a_{33}

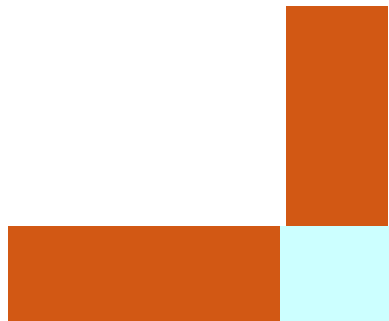

Minor



Cofactor



Engineering design

Preprocessing

Analysis

Postprocessing

Step 1

Step 2

Step 3

ENGINEERING DESIGN

PREPROCESSING

1. Create a geometric model
2. Develop the finite element model

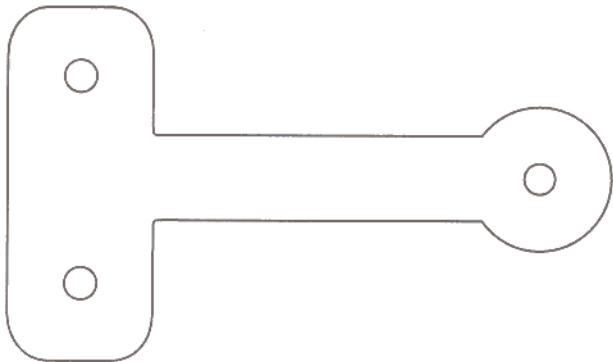

Solid model

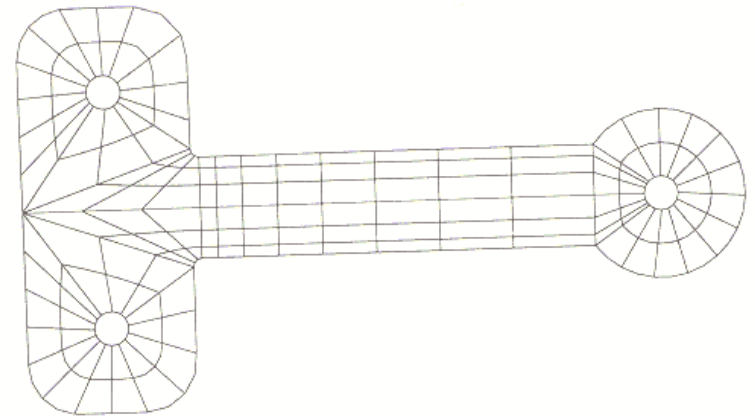

Finite element model

Engineering Design

FEM analysis scheme

Step 1: Divide the problem domain into non overlapping regions (“**elements**”) connected to each other through special points (“**nodes**”)

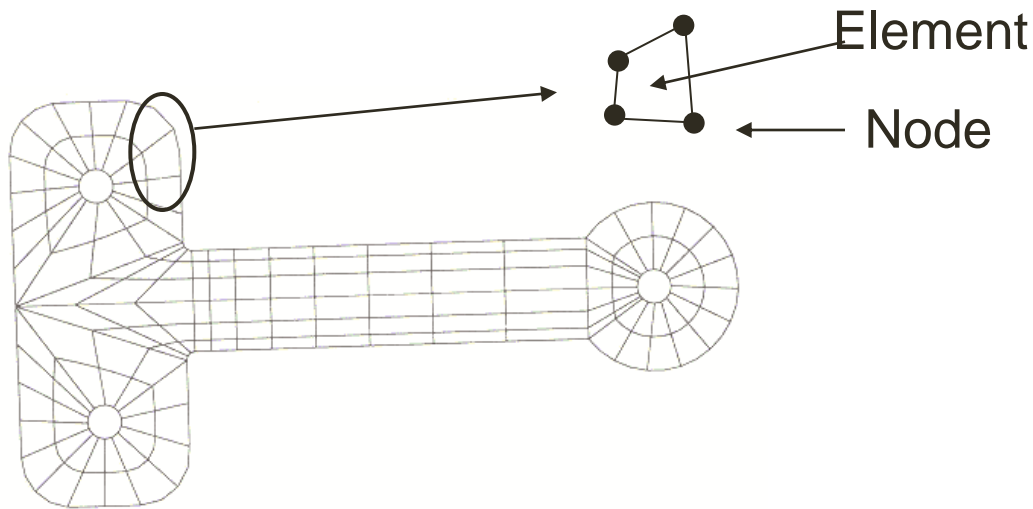

Finite element model

Engineering Design

FEM analysis scheme

Step 2: Describe the behavior of each element

Step 3: Describe the behavior of the entire body by putting together the behavior of each of the elements (this is a process known as “**assembly**”)

Some Standard FEA References

- ❖ Bathe, K.J., **Finite Element Procedures in Engineering Analysis**, Prentice-Hall, 1982, 1995.
- ❖ Beer, G. and Watson, J.O., **Introduction to Finite and Boundary Element Methods for Engineers**, John Wiley, 1993
- ❖ Bickford, W.B., **A First Course in the Finite Element Method**, Irwin, 1990.
- ❖ Burnett, D.S., **Finite Element Analysis**, Addison-Wesley, 1987.
- ❖ Chandrupatla, T.R. and Belegundu, A.D., **Introduction to Finite Elements in Engineering**, Prentice-Hall, 2002.
- ❖ Cook, R.D., Malkus, D.S. and Plesha, M.E., **Concepts and Applications of Finite Element Analysis**, 3rd Ed., John Wiley,
1989.
- ❖ Desai, C.S., **Elementary Finite Element Method**, Prentice-Hall, 1979.
- ❖ Fung, Y.C. and Tong, P., **Classical and Computational Solid Mechanics**, World Scientific, 2001.
- ❖ Grandin, H., **Fundamentals of the Finite Element Method**, Macmillan, 1986.
- ❖ Huebner, K.H., Thorton, E.A. and Byrom, T.G., **The Finite Element Method for Engineers**, 3rd Ed., John Wiley, 1994.
- ❖ Knight, C.E., **The Finite Element Method in Mechanical Design**, PWS-KENT, 1993.
- ❖ Logan, D.L., **A First Course in the Finite Element Method**, 2nd Ed., PWS Engineering, 1992.
- ❖ Moaveni, S., **Finite Element Analysis – Theory and Application with ANSYS**, 2nd Ed., Pearson Education, 2003.
- ❖ Pepper, D.W. and Heinrich, J.C., **The Finite Element Method: Basic Concepts and Applications**, Hemisphere, 1992.
- ❖ Pao, Y.C., **A First Course in Finite Element Analysis**, Allyn and Bacon, 1986.
- ❖ Rao, S.S., **Finite Element Method in Engineering**, 3rd Ed., Butterworth-Heinemann, 1998.
- ❖ Reddy, J.N., **An Introduction to the Finite Element Method**, McGraw-Hill, 1993.
- ❖ Ross, C.T.F., **Finite Element Methods in Engineering Science**, Prentice-Hall, 1993.
- ❖ Stasa, F.L., **Applied Finite Element Analysis for Engineers**, Holt, Rinehart and Winston, 1985.
- ❖ Zienkiewicz, O.C. and Taylor, R.L., **The Finite Element Method**, Fourth Edition, McGraw-Hill, 1977, 1989.

Dividing objects

Object



Elements

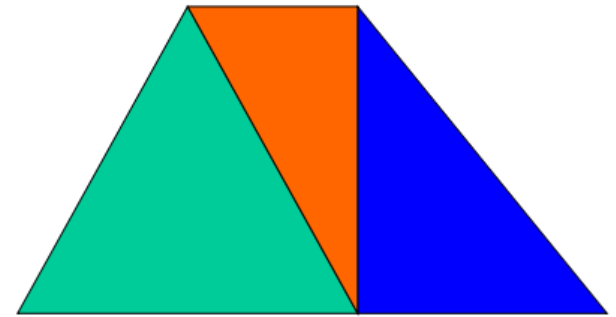

Nodes

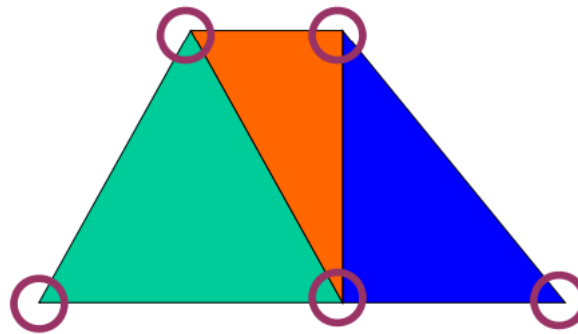

NEED FOR FEA

MECHANICAL ENGINEERING

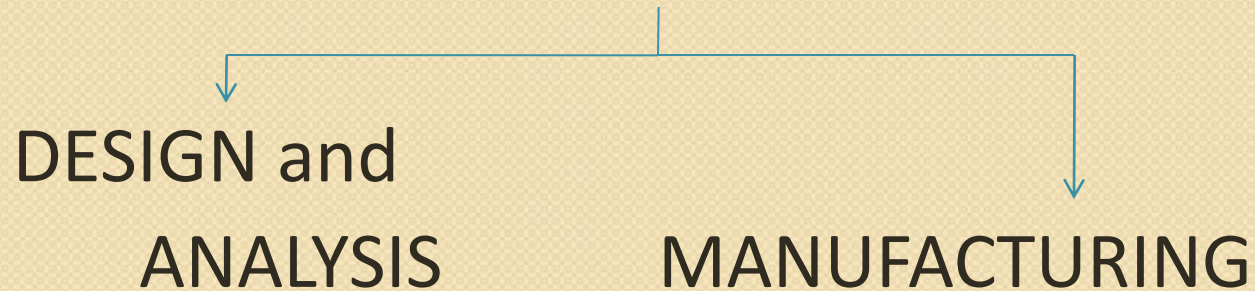

- . Loads
 - . Size
 - . Shape
 - . Appearance
 - . Applications

METHODS OF ENGINEERING ANALYSIS

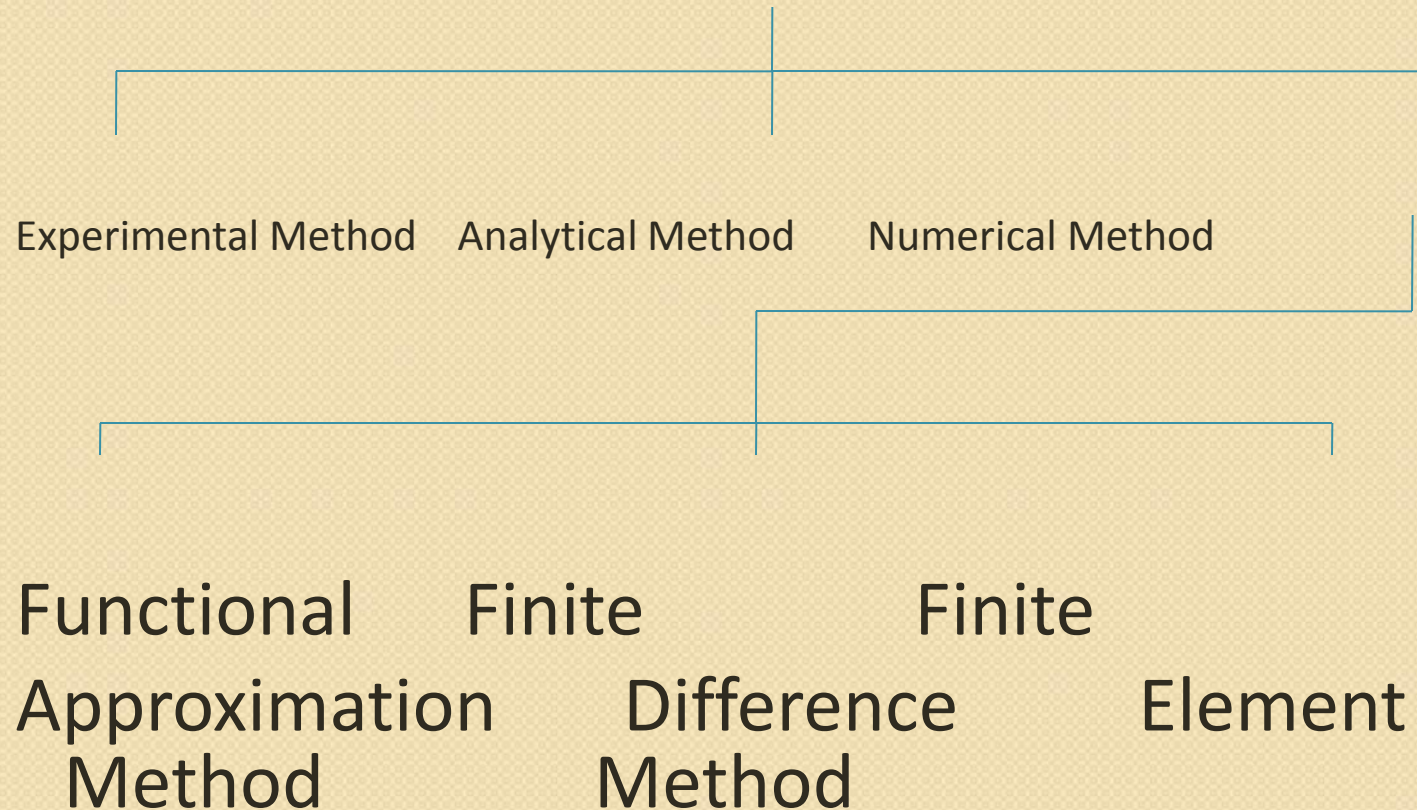

EXPERIMENTAL METHOD (Prototype)

- Costly
- Time consuming
- Can't predict exact results

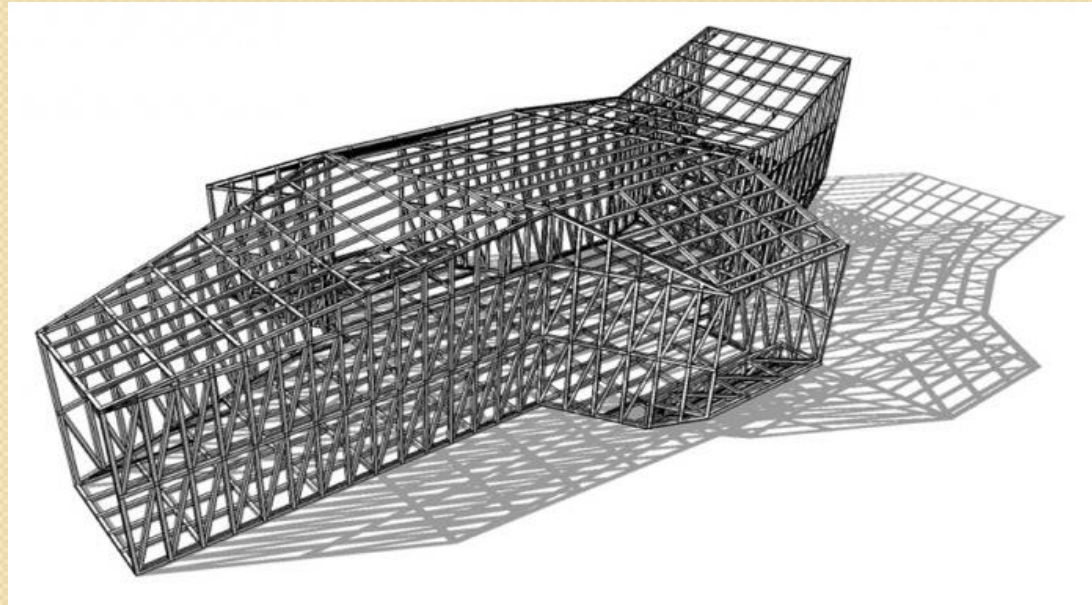

Analytical method

- Time consuming
- Need all inputs
- Limited solutions

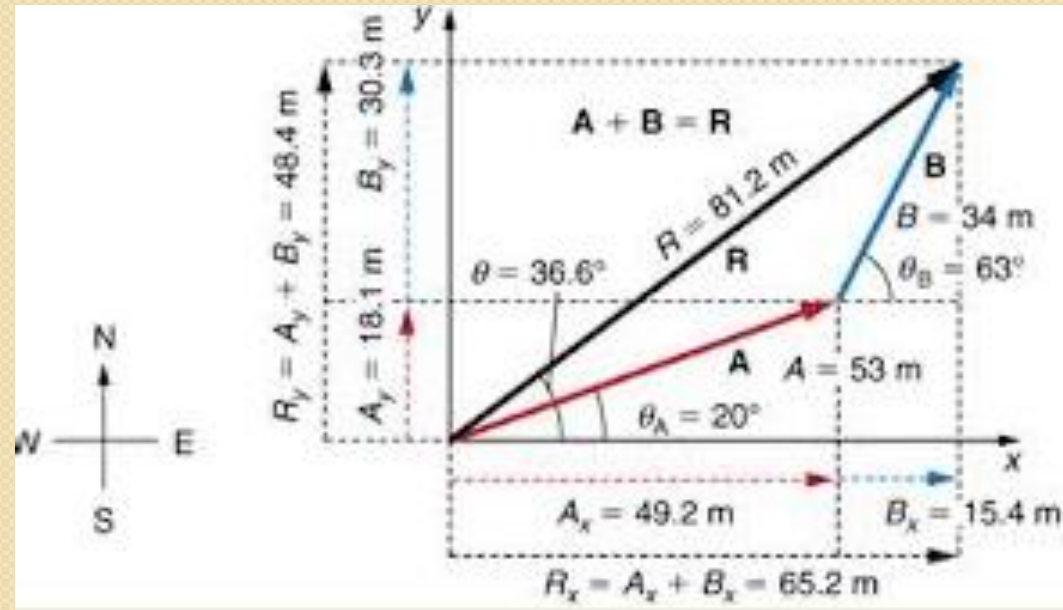

Numerical method

- Always get approximate but acceptable solution
- Various methods available
- Supported with software

Romberg Integration + Richardson Extrapolation

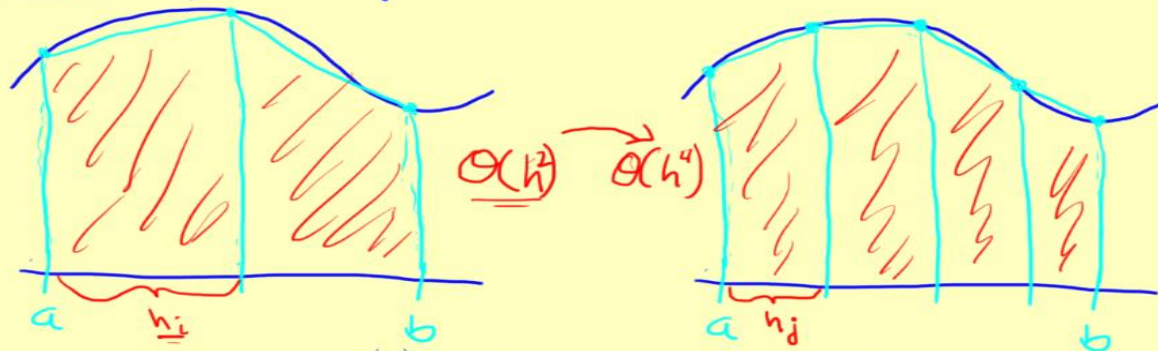

$$\underline{I = I(h_j) + E(h_j)} \approx I(h_j) + \frac{I(h_j) - I(h_i)}{\left(\frac{h_i}{h_j}\right)^2 - 1}$$

$$\text{If } h_i = 2h_j, \underline{I = \frac{4}{3}I(h_j) - \frac{1}{3}I(h_i)}$$

Functional approximation (Rayleigh Ritz method)

- Suitable for structural problems
- Approximate solution



Functional approximation (Galerkin's method)

- Heat transfer, CFD problems
- Approximate solution

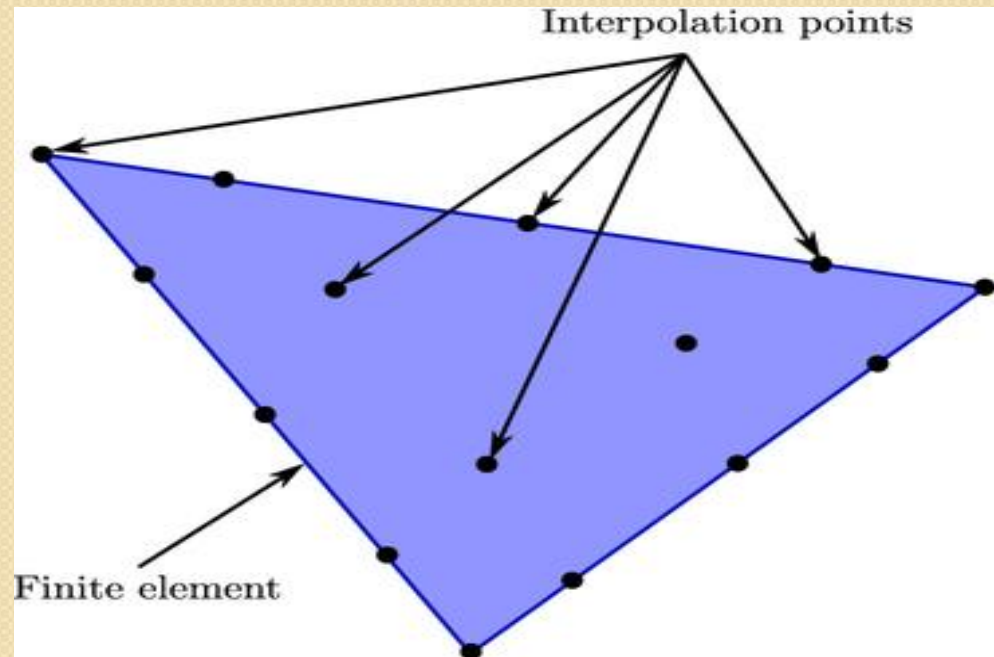

Finite Difference Method (FDM)

- Suitable for known boundary conditions
- Suitable for 2D problems

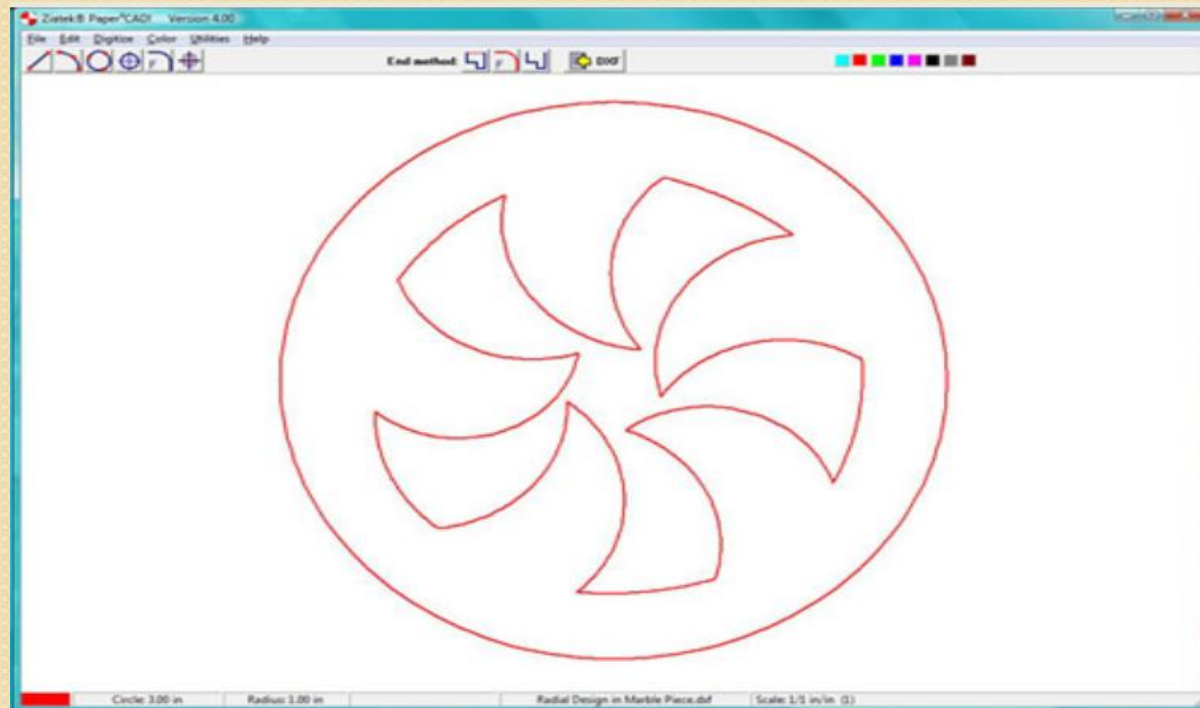

Finite Element Analysis (FEA)

- Overcomes all disadvantages of above mentioned methods
- Can get exact solutions



TYPES OF FINITE ELEMENT

1-D (Line) Element



(Spring, truss, beam, pipe, etc.)

2-D (Plane) Element

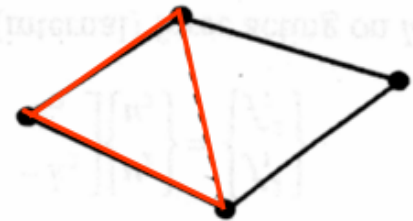

(Membrane, plate, shell, etc.)

3-D (Solid) Element

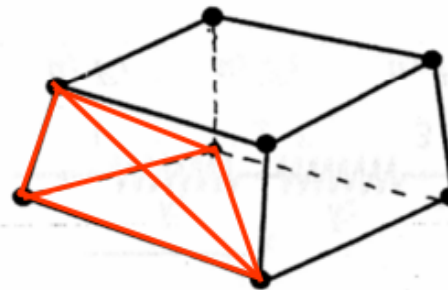

ADVANTAGES

- FEM can handle irregular geometry.
- Non-homogenous materials can be handled easily.
- Dynamic effects can be included.
- Handles general load conditions easily.
- Altering the element model with different loads, boundary conditions etc done easily.

FEM Software

1. ANSYS
2. ALGER
3. COSMOS/M
4. STARDYNE, STAAD-PRO, GT-STRUDEL
5. IMAGES-3D
6. CAFEM
7. NISA
8. ADINA
9. MSC/NASTRAN
10. SAP

PROCEDURE FOR FEA

- **PRE PROCESSING**

1. DISCRETIZATION
2. NUMBERING OF NODES AND ELEMENTS

- **ANALYSIS**

1. SELECTION OF DISPLACEMENT FUNCTIONS
2. DEFINE THE MATERIAL BEHAVIOUR
3. DERIVATION OF ELEMENT STIFFNESS MATRIX EQUATIONS
4. ASSEMBLE THE ELEMENT EQUATIONS
5. APPLY BOUNDARY CONDITIONS
6. SOLUTION TO UNKNOWN DISPLACEMENTS

- **POST PROCESSING**

1. INTERPRET THE RESULTS

Regular and Irregular Geometry

Regular polygons



Triangle



Quadrilateral



Pentagon



Hexagon



Heptagon

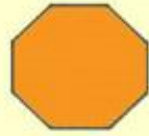

Octagon



Nonagon

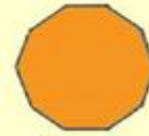

Decagon



Triangle



Quadrilateral

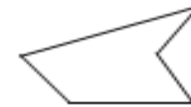

Pentagon



Hexagon



Heptagon



Octagon



Nonagon



Decagon

Homogeneous and non-homogeneous materials

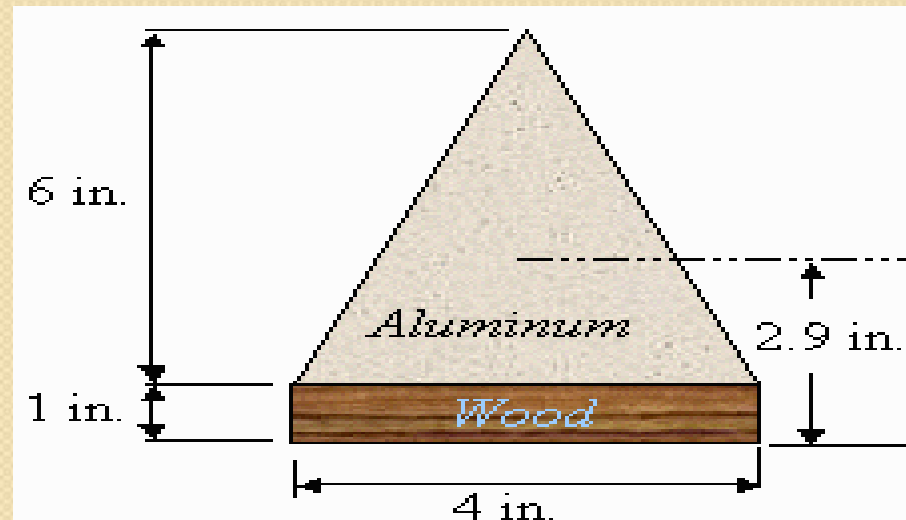

Dynamic effects

C2500 PICKUP TRUCK MODEL (NCAC V8)

Time = 0.033

Contours of Effective Stress ($\nu\text{-m}$)

max ipt. value

min=0, at elem# 3500

max=532.405, at elem# 286

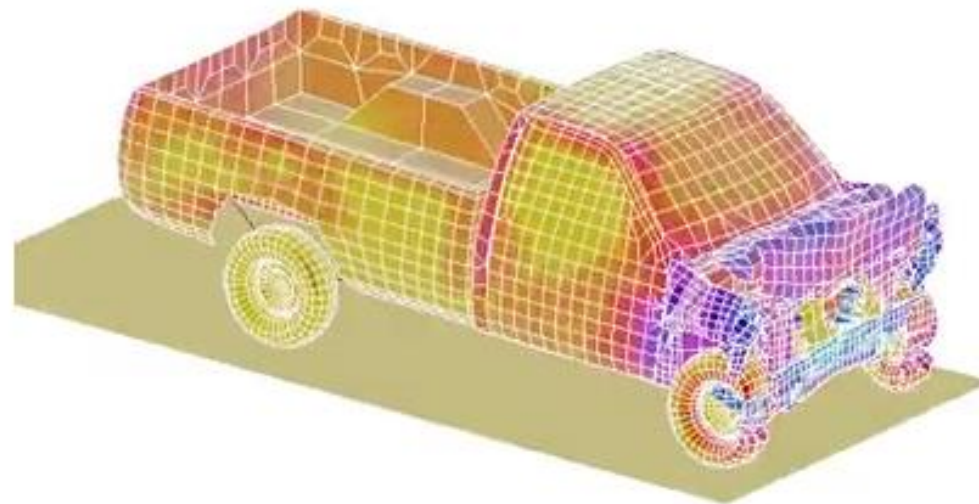

Fringe Levels

5.000e+02

4.500e+02

4.000e+02

3.500e+02

3.000e+02

2.500e+02

2.000e+02

1.500e+02

1.000e+02

5.000e+01

0.000e+00

Different loading conditions

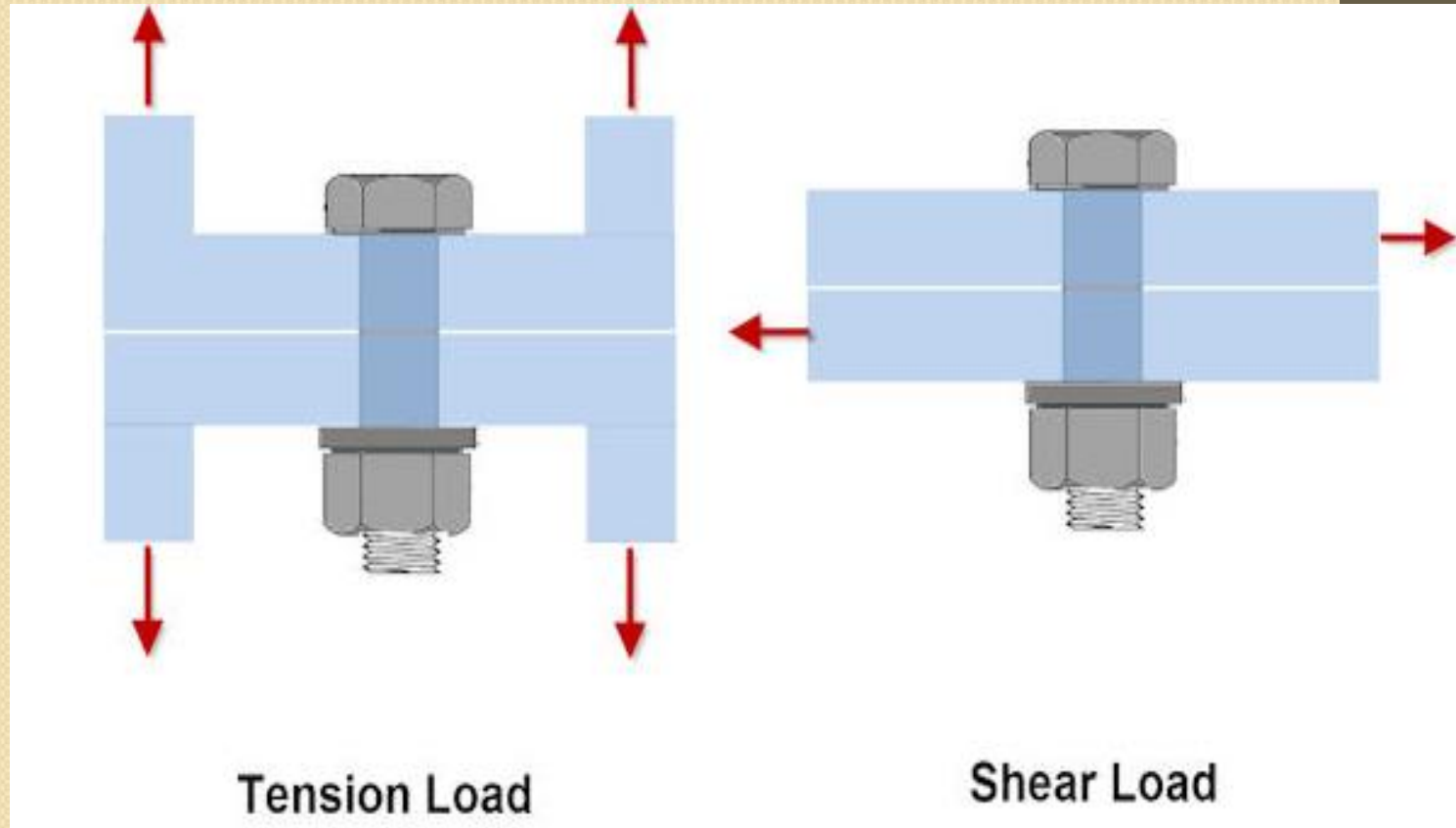

APPLICATIONS

- **Civil**
- **Aircraft**
- **Mechanical**
- **Heat conduction**
- **Hydraulic Engineering**
- **Electrical Machines**
- **Nuclear Engineering**
- **Geo mechanics**
- **Biomedical Engineering**

Civil structure

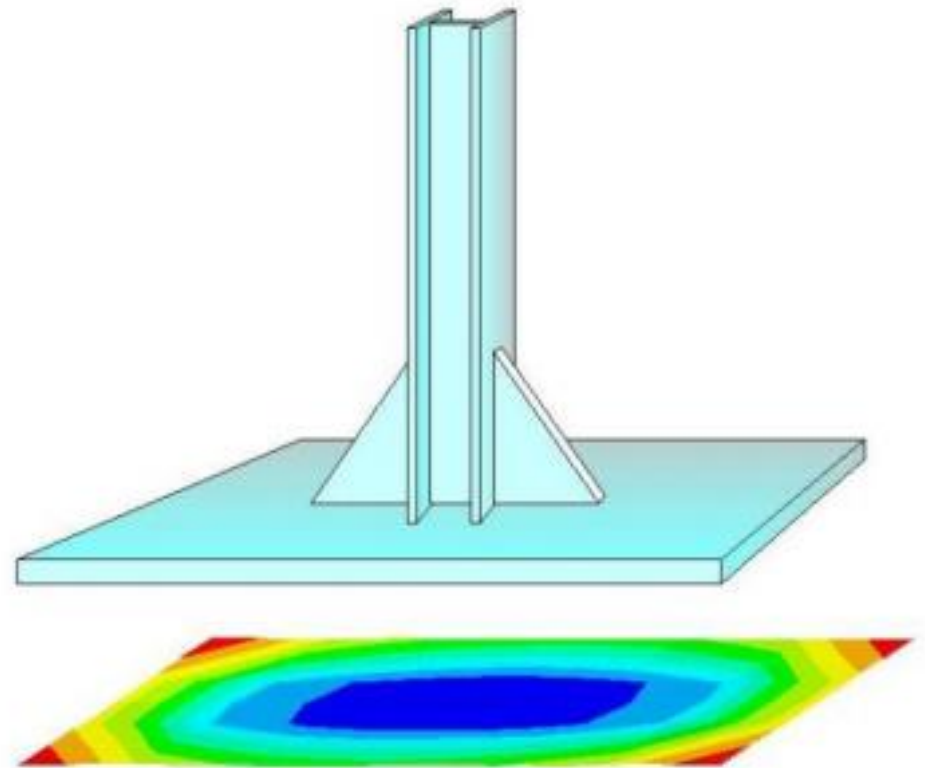

Footing design with soil mechanics module

Aerodynamics Design

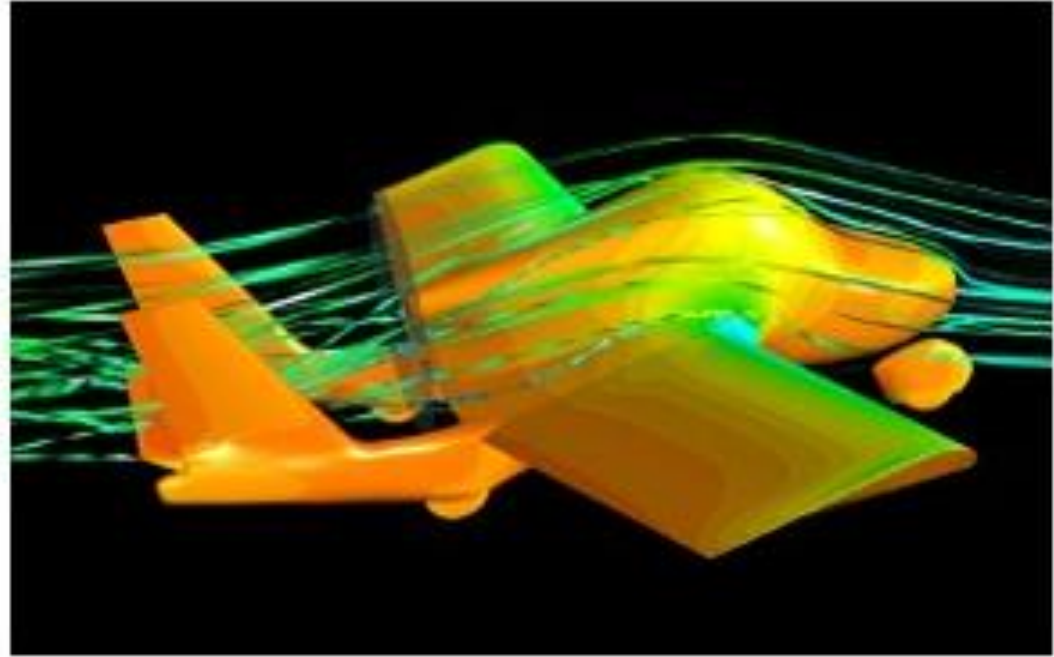

A specialty virtual blade modeler plug-in to ANSYS FLUENT enabled Terrafugia engineers to model the vehicle's propeller under near-stall conditions. This simulation helped ensure the safety of the aircraft while in flight.

Crane hook design

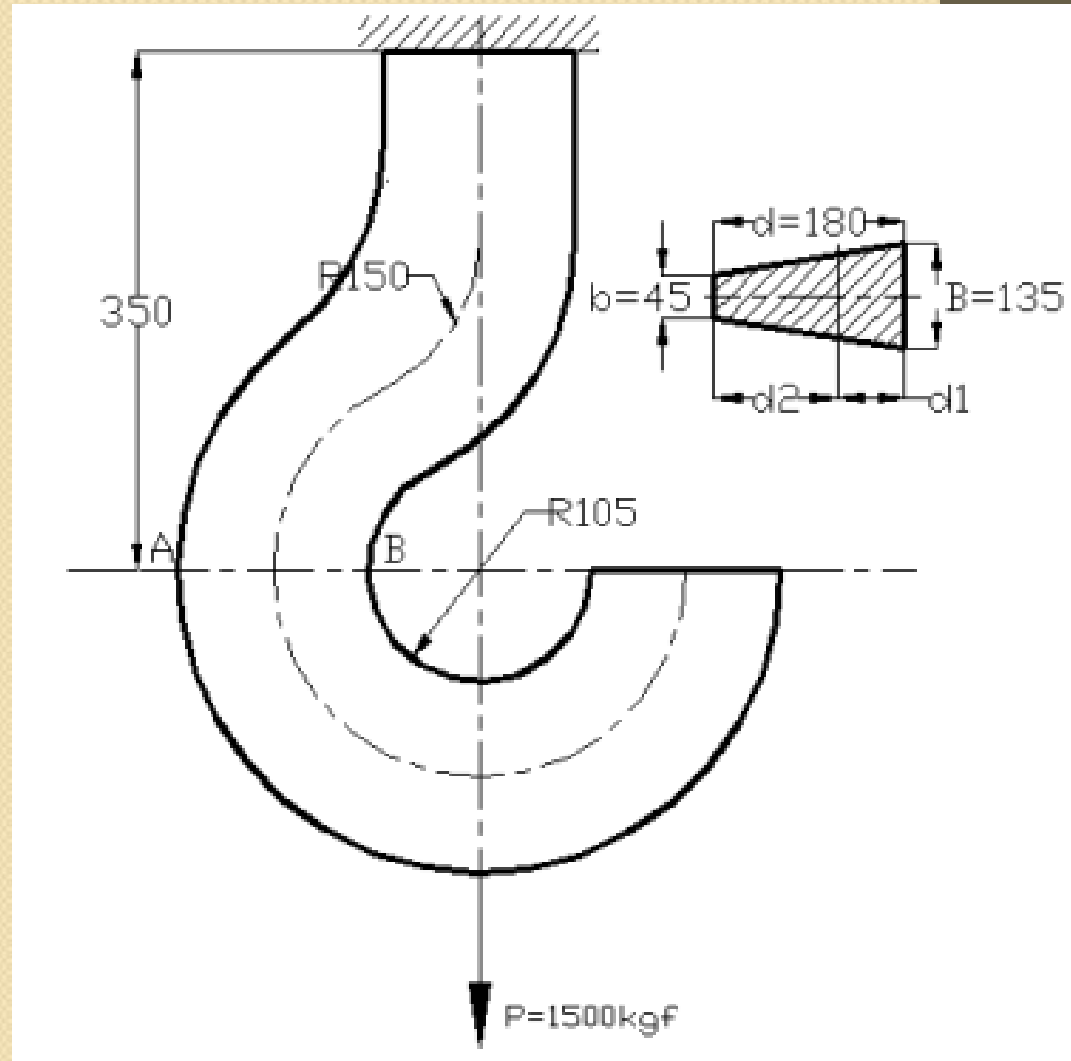

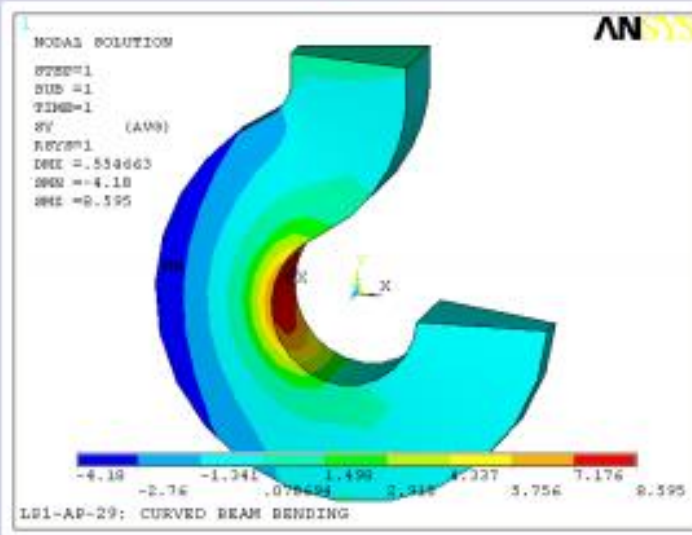
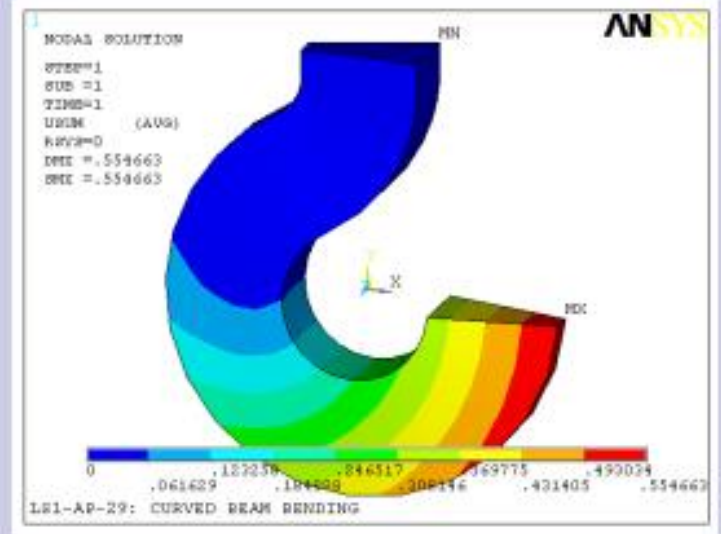
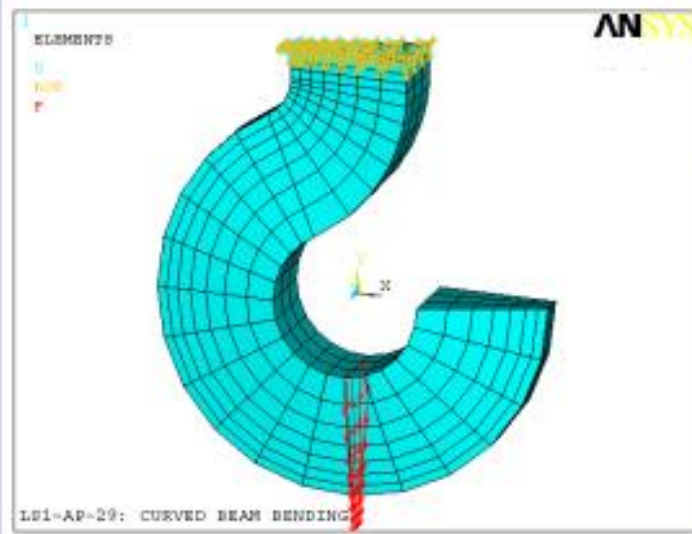

Stress - kgf/mm ²	THEORY	ANSYS
A	-4.32	-4.18
B	8.37	8.595

Convection problem

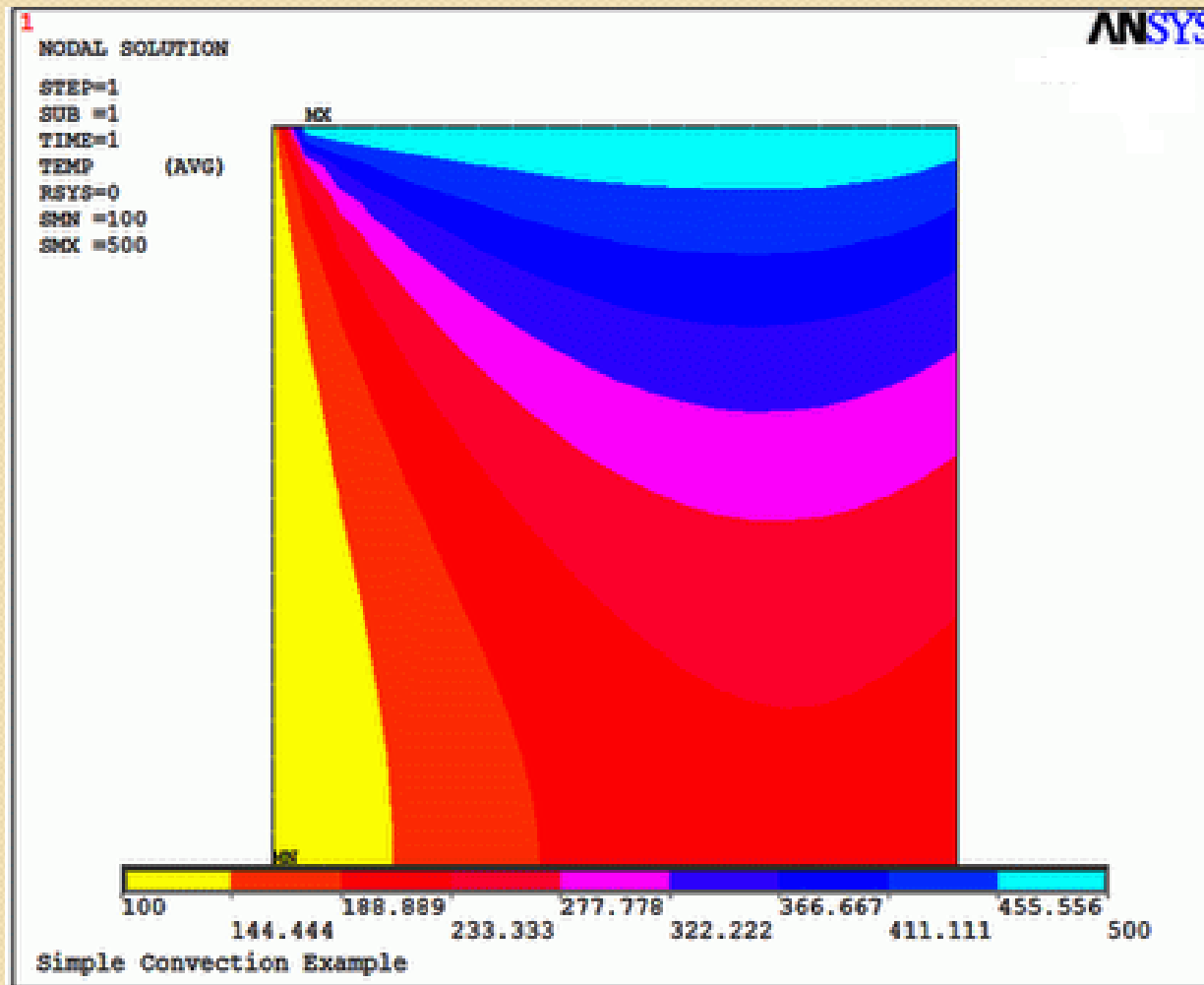

Hydraulic turbine

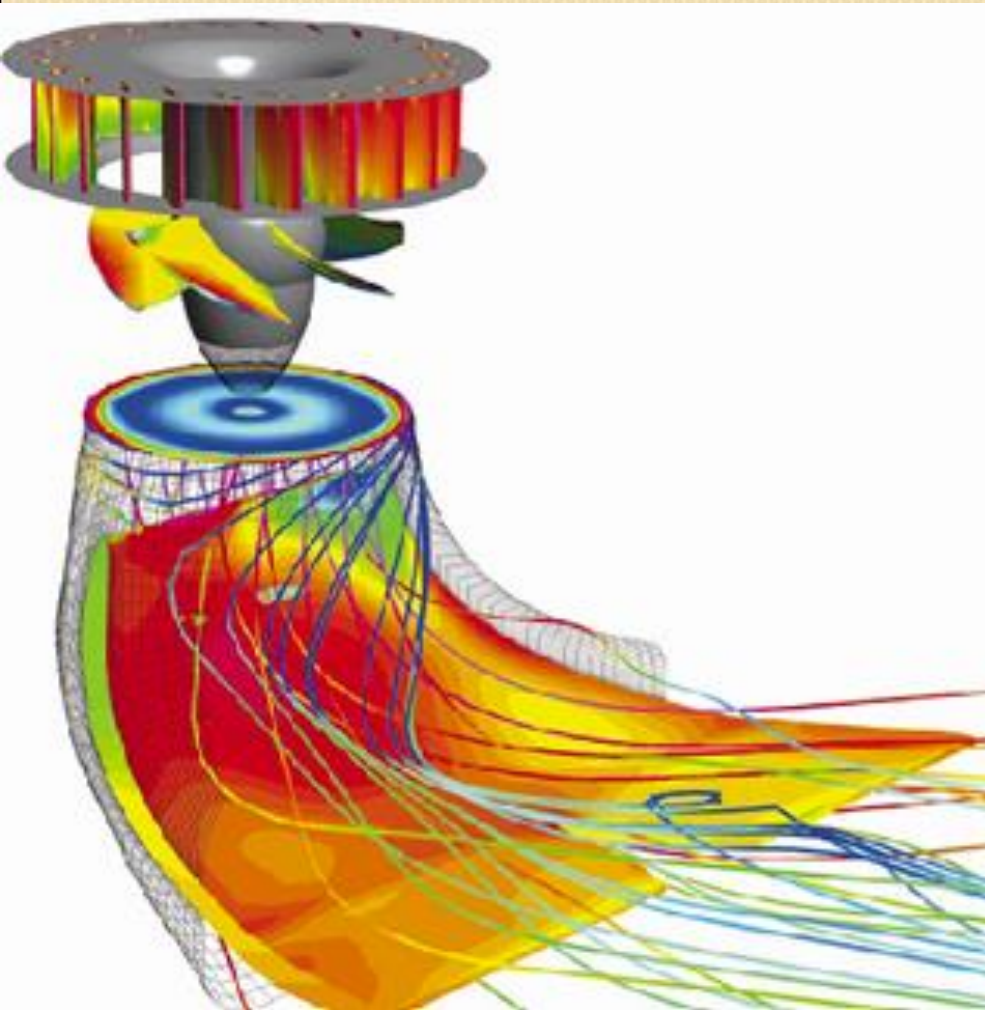

Electric motor Design

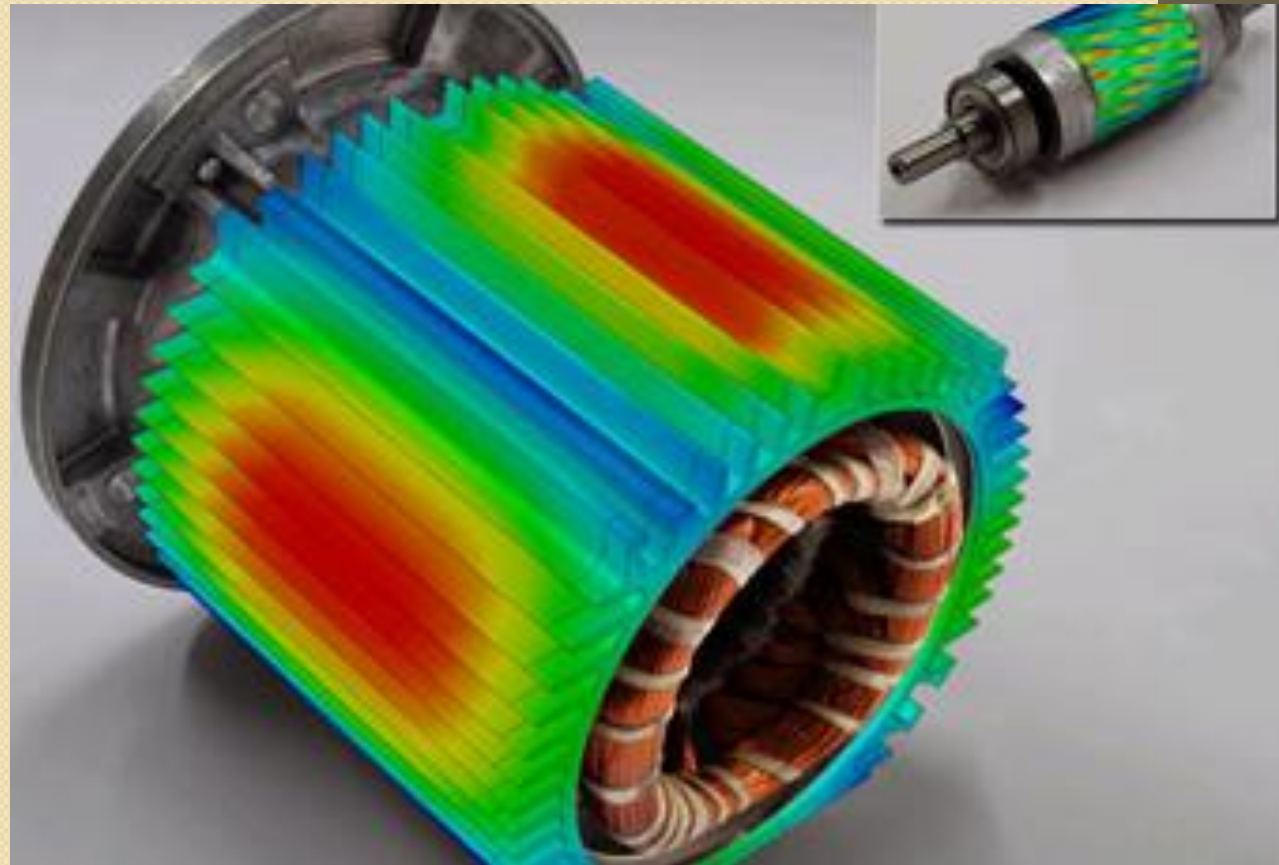

Bio medical applications

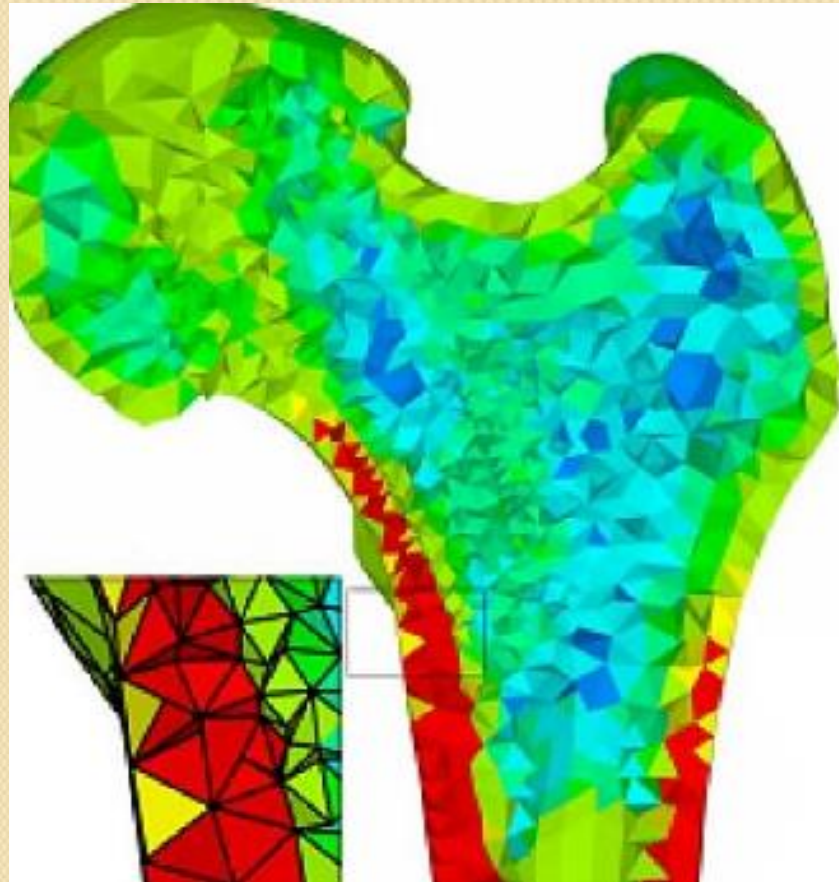

Box spanner design

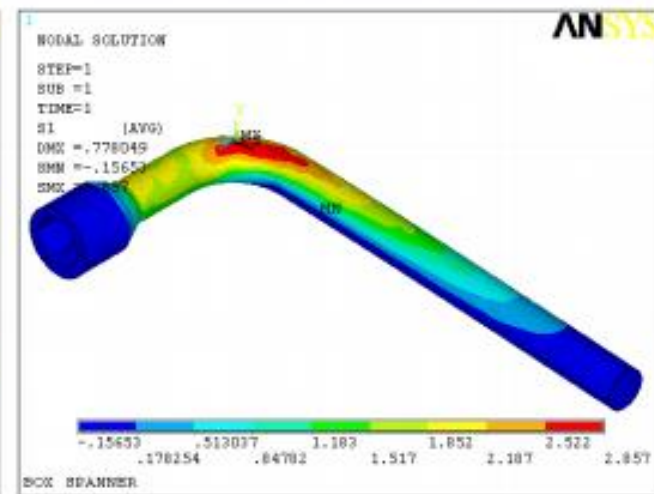
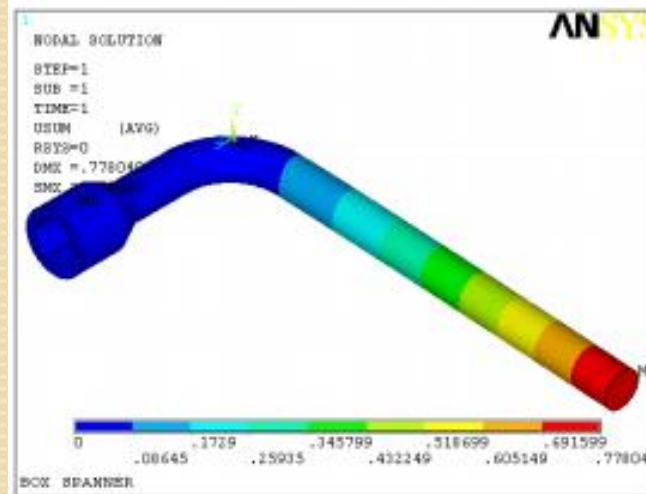
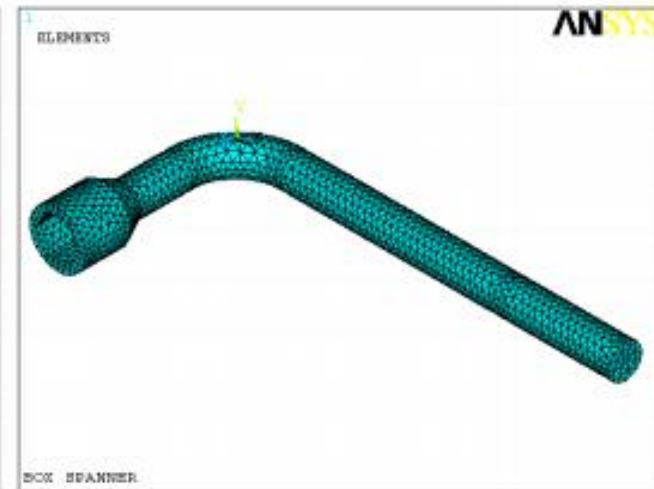
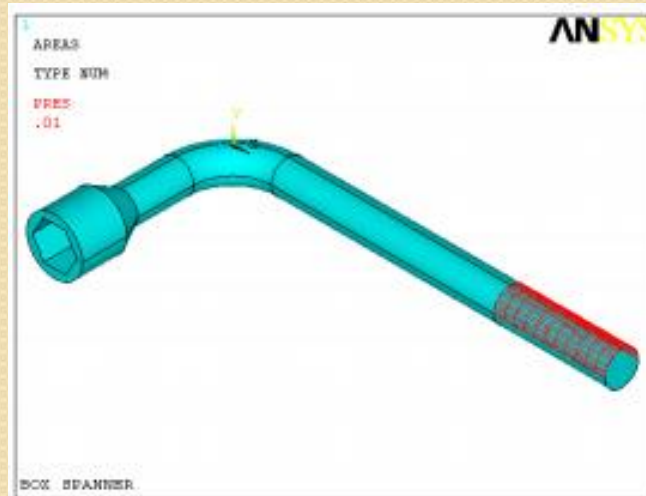

Bracket design

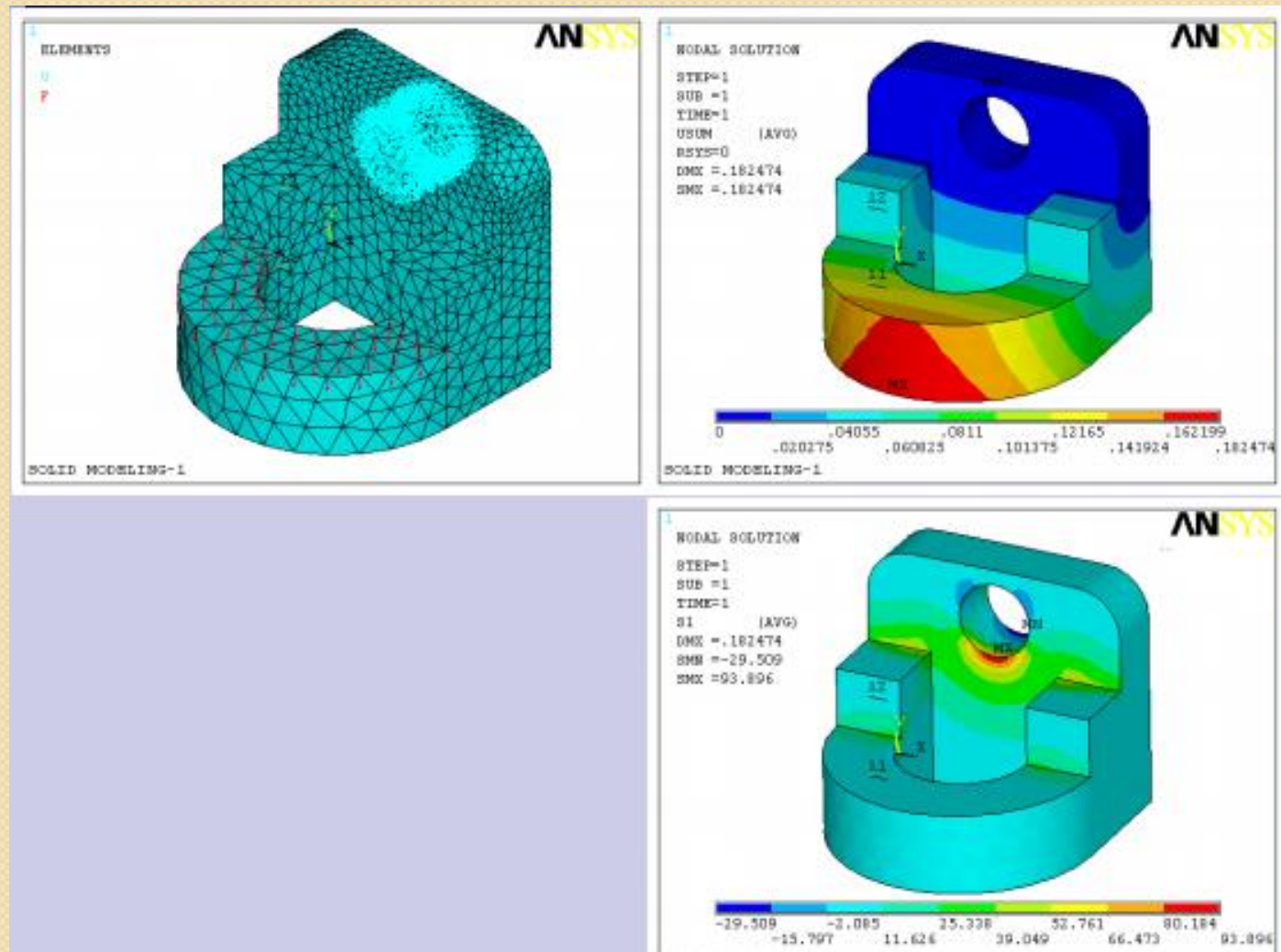

Truck chassis design

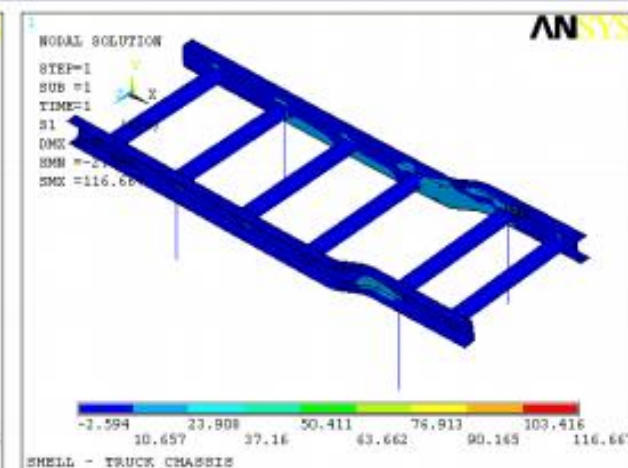
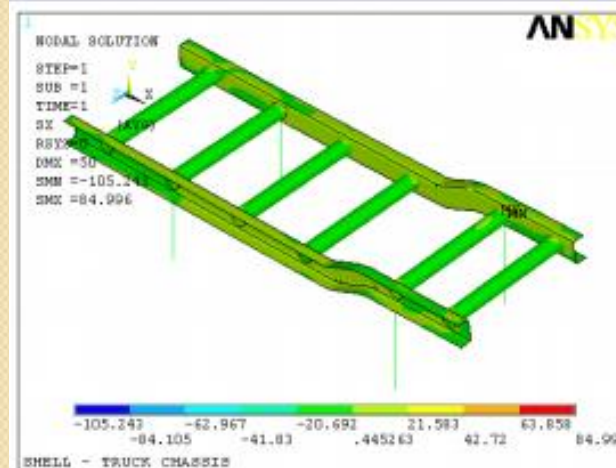
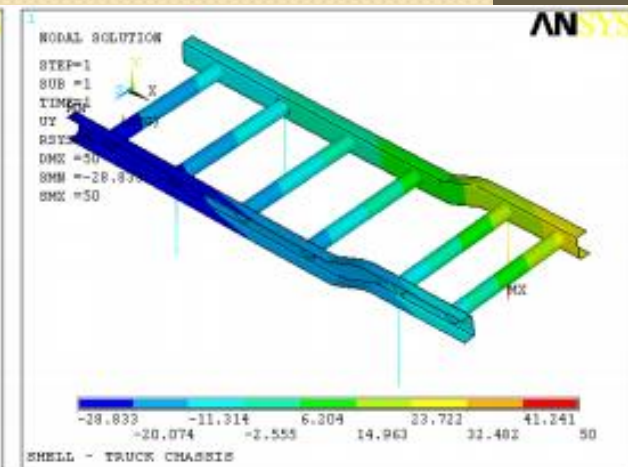
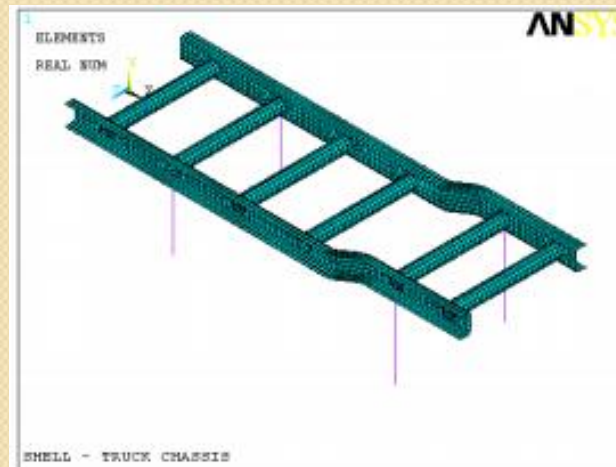

Fan impeller design

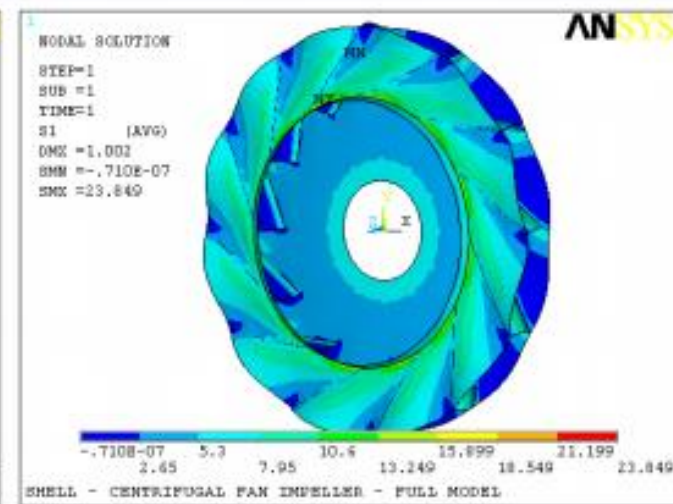
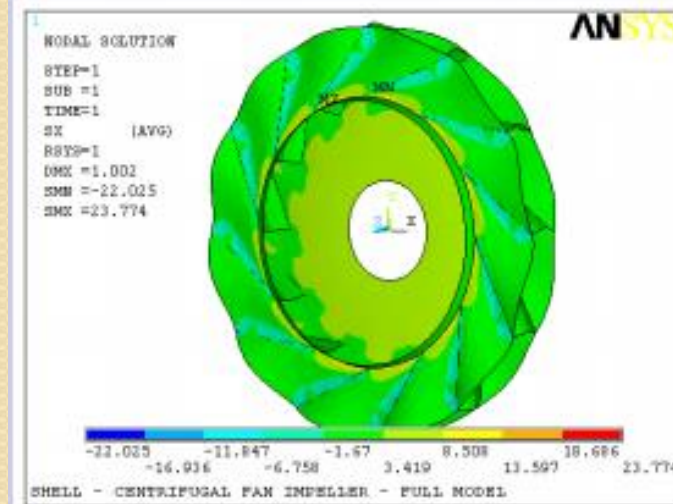
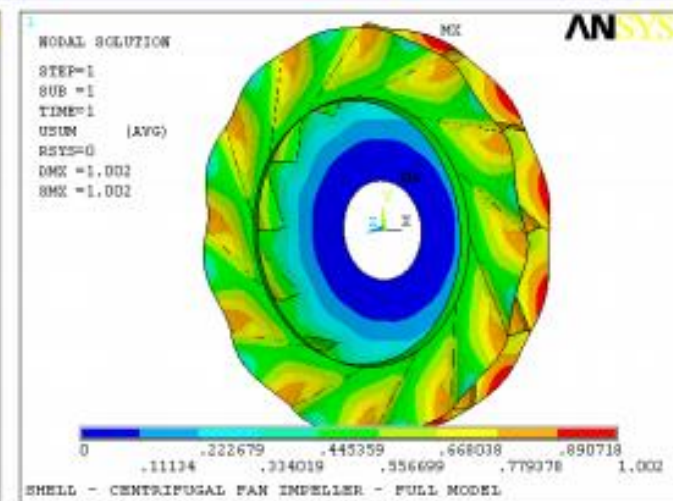
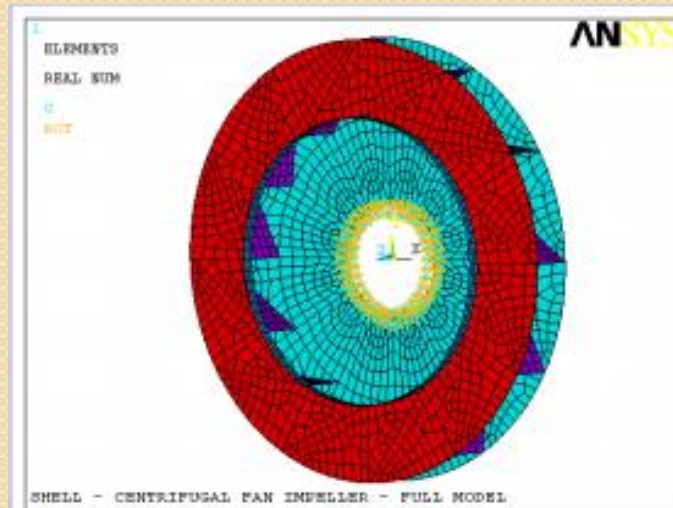

Chain sprocket

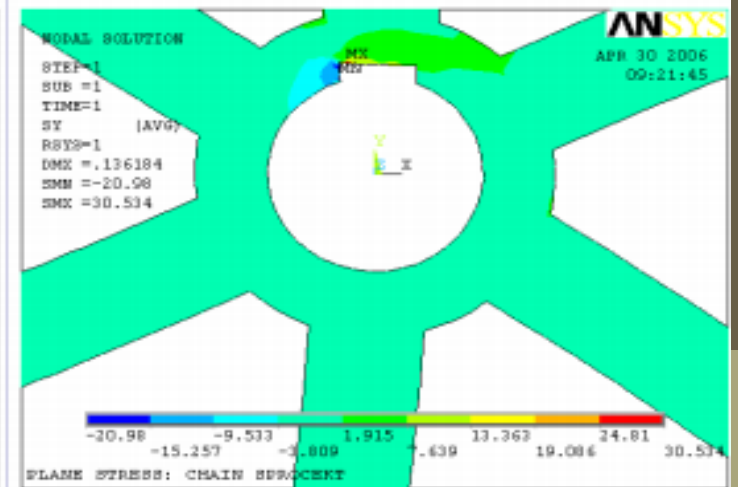
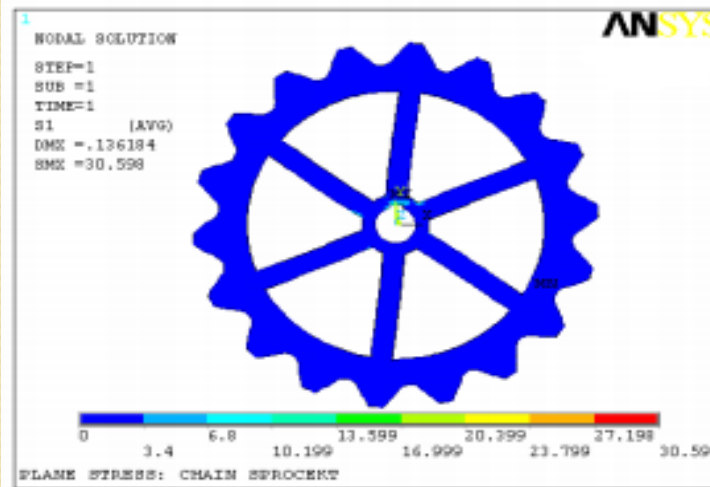
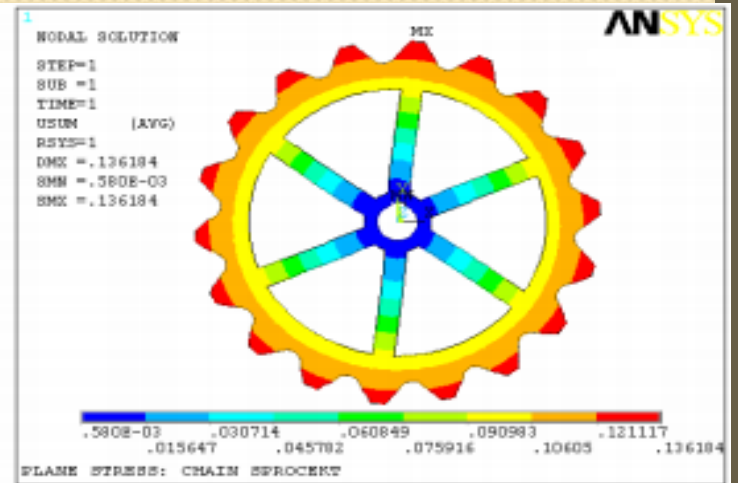
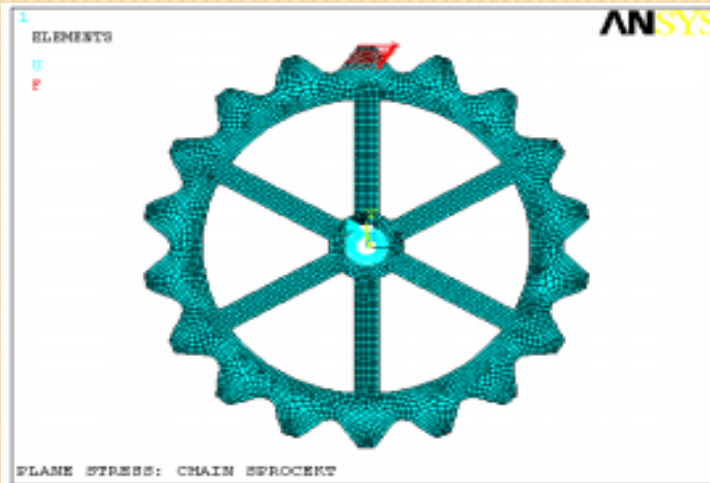

Bicycle frame design

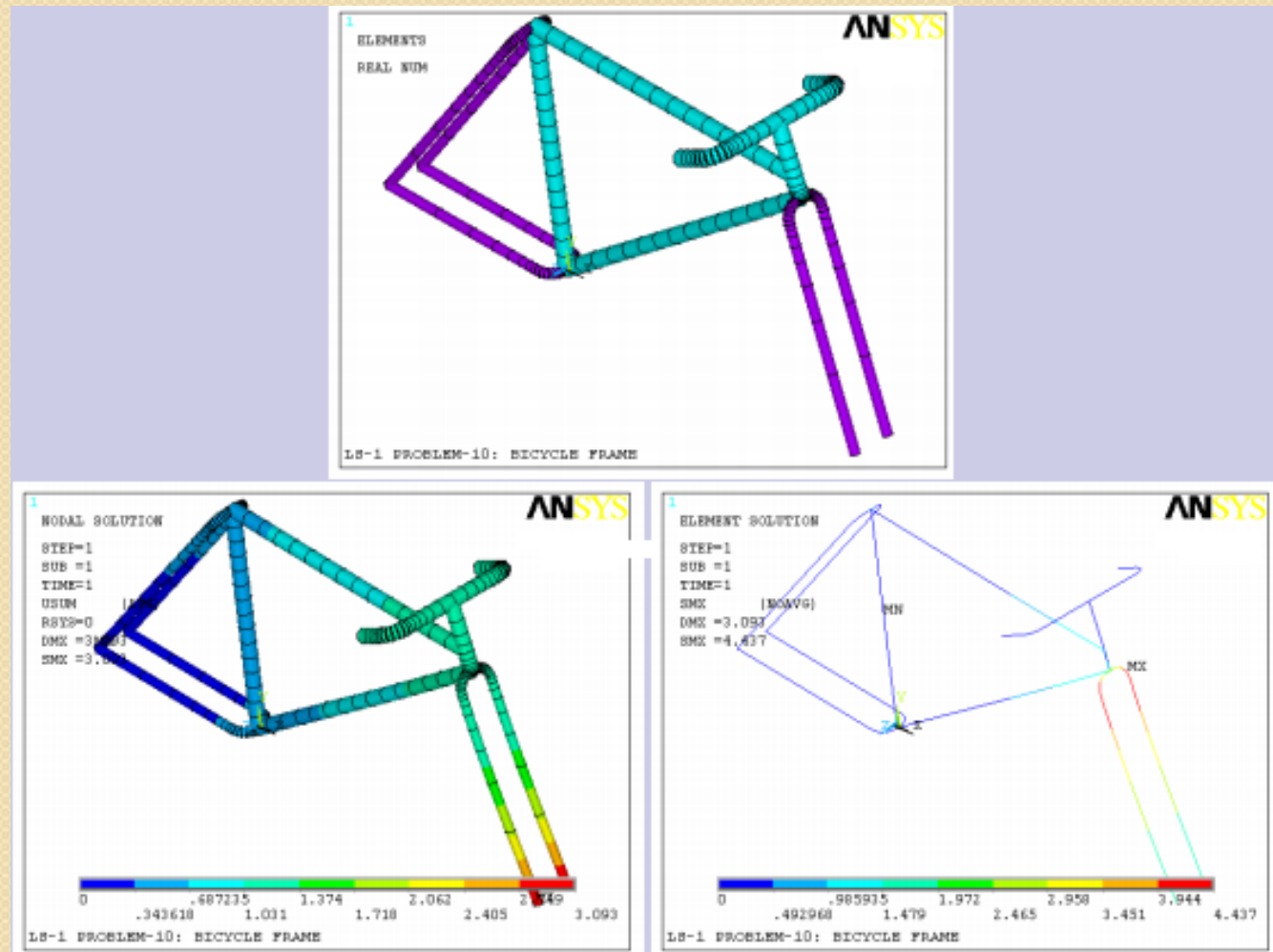

Example 1: Deformation of a bar with a non-uniform circular cross section subject a force P . (Weight of the bar is negligible).

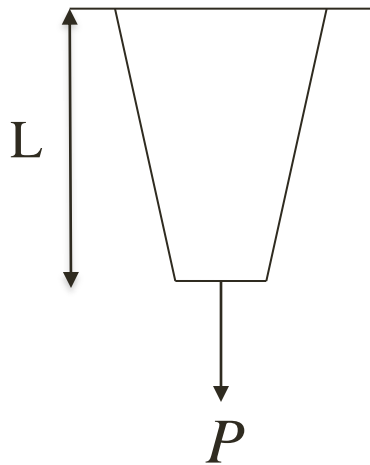

$$\begin{aligned}
 R - k_1(u_2 - u_1) &= 0 \\
 k_1(u_2 - u_1) - k_2(u_3 - u_2) &= 0 \\
 k_2(u_3 - u_2) - k_3(u_4 - u_3) &= 0 \\
 k_3(u_4 - u_3) - k_4(u_5 - u_4) &= 0 \\
 k_4(u_5 - u_4) - P &= 0
 \end{aligned}
 \Rightarrow
 \begin{bmatrix}
 k_1 & -k_1 & 0 & 0 & 0 & 0 \\
 -k_1 & k_1 + k_2 & -k_2 & 0 & 0 & 0 \\
 0 & -k_2 & k_2 + k_3 & -k_3 & 0 & 0 \\
 0 & 0 & -k_3 & k_3 + k_4 & -k_4 & 0 \\
 0 & 0 & 0 & -k_4 & k_4 + k_5 & -k_5 \\
 0 & 0 & 0 & 0 & -k_5 & k_5
 \end{bmatrix}
 \begin{Bmatrix}
 u_1 \\
 u_2 \\
 u_3 \\
 u_4 \\
 u_5 \\
 u_6
 \end{Bmatrix}
 =
 \begin{Bmatrix}
 -R \\
 0 \\
 0 \\
 0 \\
 0 \\
 P
 \end{Bmatrix}
 \Rightarrow [\mathbf{K}]\{\mathbf{u}\} = \{\mathbf{P}\} - \{\mathbf{R}\}$$

What is a Finite Element Method

- View the problem domain as a collection of subdomains (elements)
- Solve the problem at each subdomain
- Assemble elements to find the global solution
- Solution is guaranteed to converge to the correct solution if proper theory, element formulation and solution procedure are followed.

History of Finite Element Methods

- 1941 – Hrenikoff proposed framework method
- 1943 – Courant used principle of stationary potential energy and piecewise function approximation
- 1953 – Stiffness equations were written and solved using digital computers.
- 1960 – Clough made up the name “finite element method”
- 1970s – FEA carried on “mainframe” computers
- 1980s – FEM code run on PCs
- 2000s – Parallel implementation of FEM (large-scale analysis, virtual design)

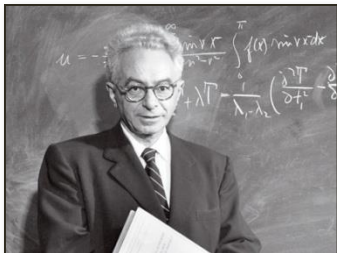

Courant



Clough

Applications of Finite Element Methods

- *Structural & Stress Analysis*
- *Thermal Analysis*
- *Dynamic Analysis*
- *Acoustic Analysis*
- *Electro-Magnetic Analysis*
- *Manufacturing Processes*
- *Fluid Dynamics*
- *Financial Analysis*

Applications: Aerospace Engineering (AE)

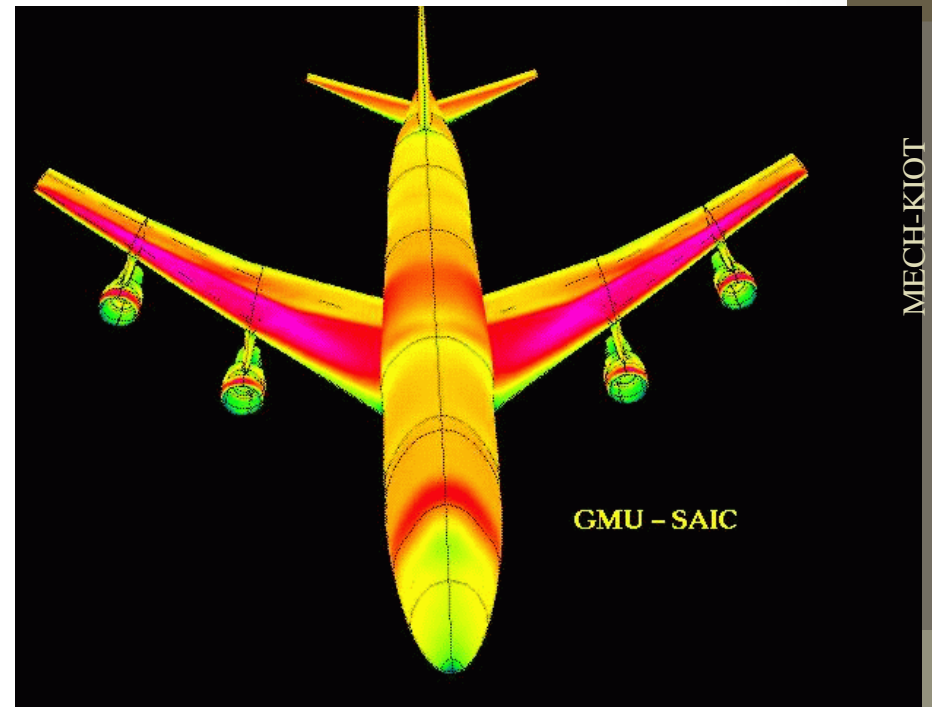
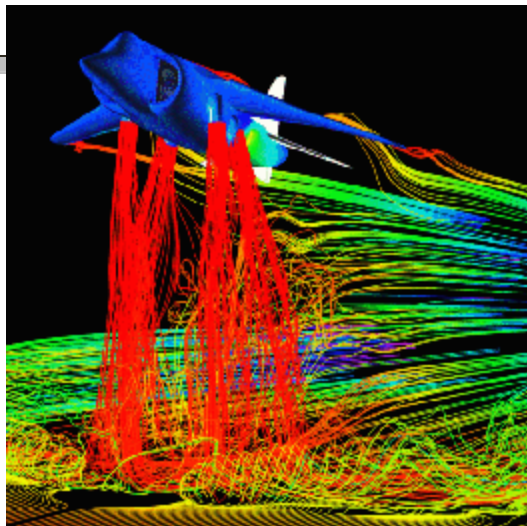
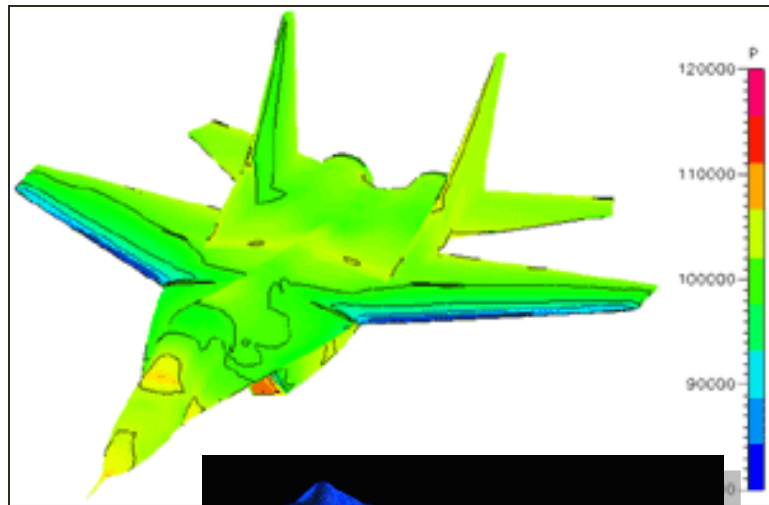

Applications: Civil Engineering (CE)

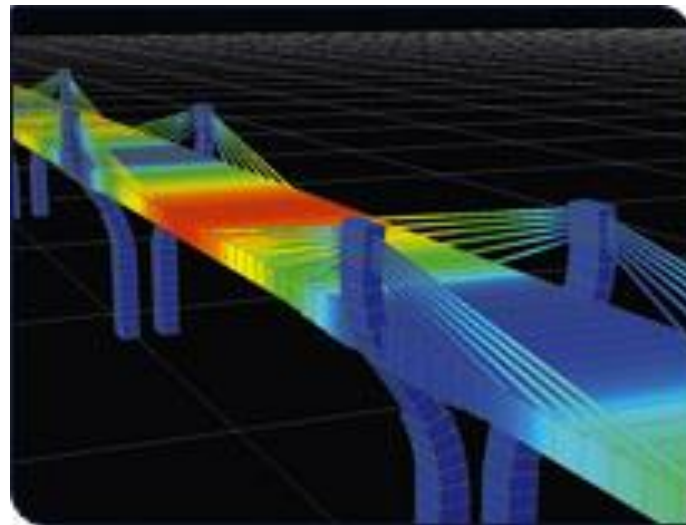
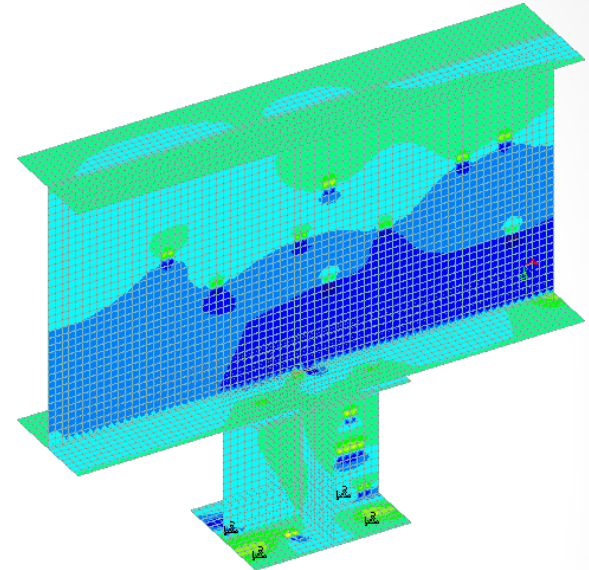

Applications: Electrical Engineering (EE)

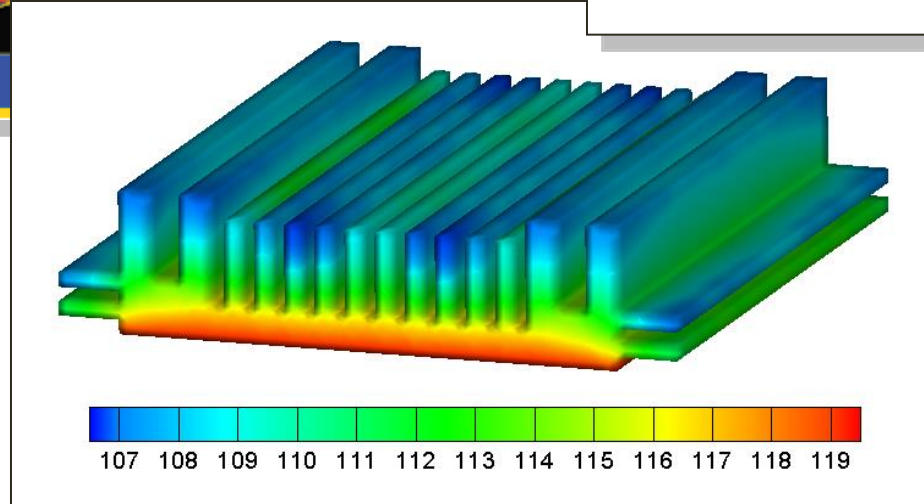
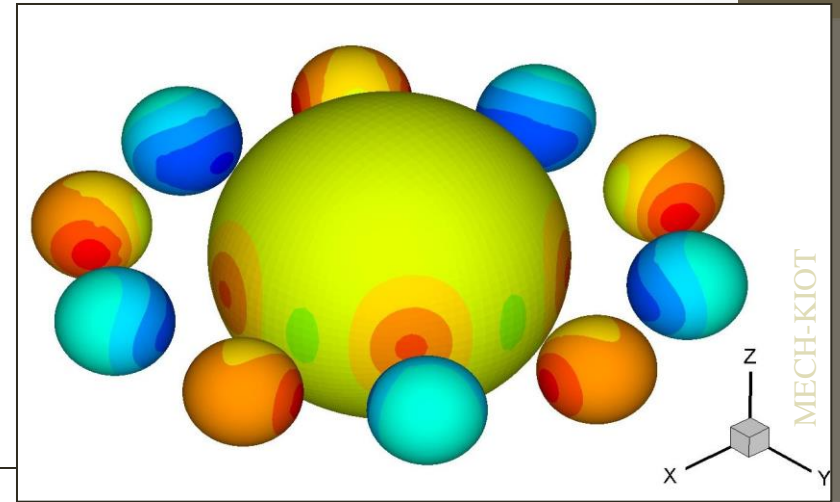
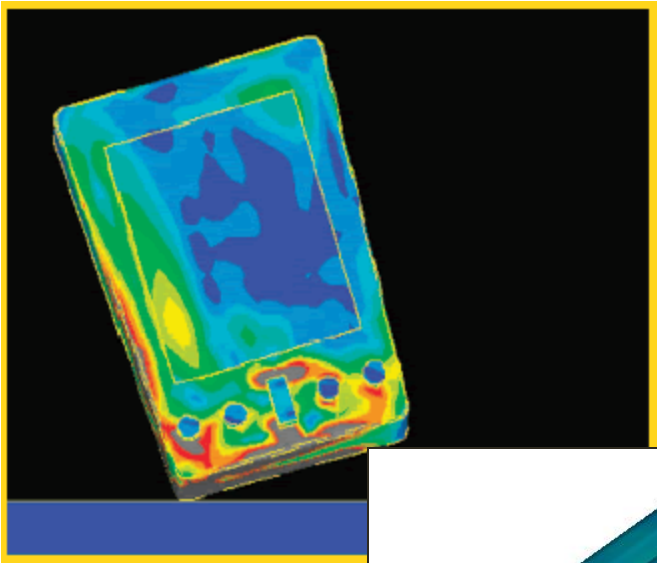

Applications: Biomedical Engineering (BE)

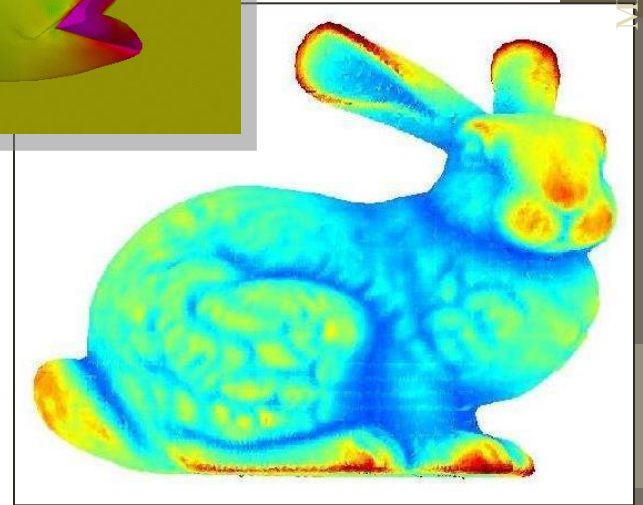
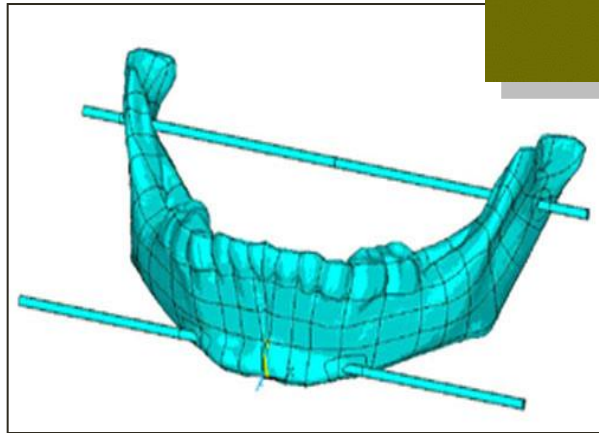
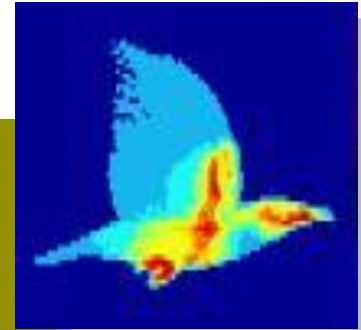
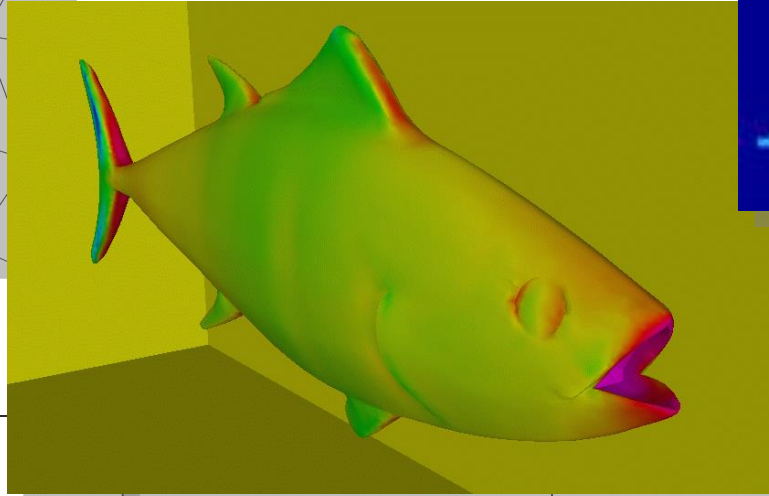
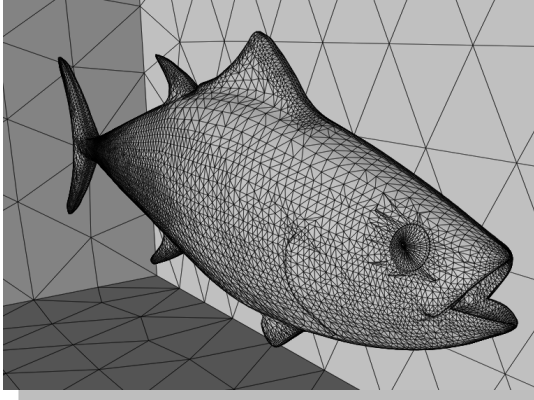

The Future – Virtual Engineering



Review of Basic Statics and Mechanics of Materials

- Static equilibrium conditions/free-body diagram
- Stress, strain and deformation
- Constitutive law – Hooke's law
- Analysis of axially loaded bar, truss, beam and frame
- 2-D elasticity

Review of Matrix Algebra

- Matrix operation: addition, subtraction, multiplication
- Basic definitions and properties of matrix
- Inverse of matrix and solution of linear equations
- etc

Global and local axes

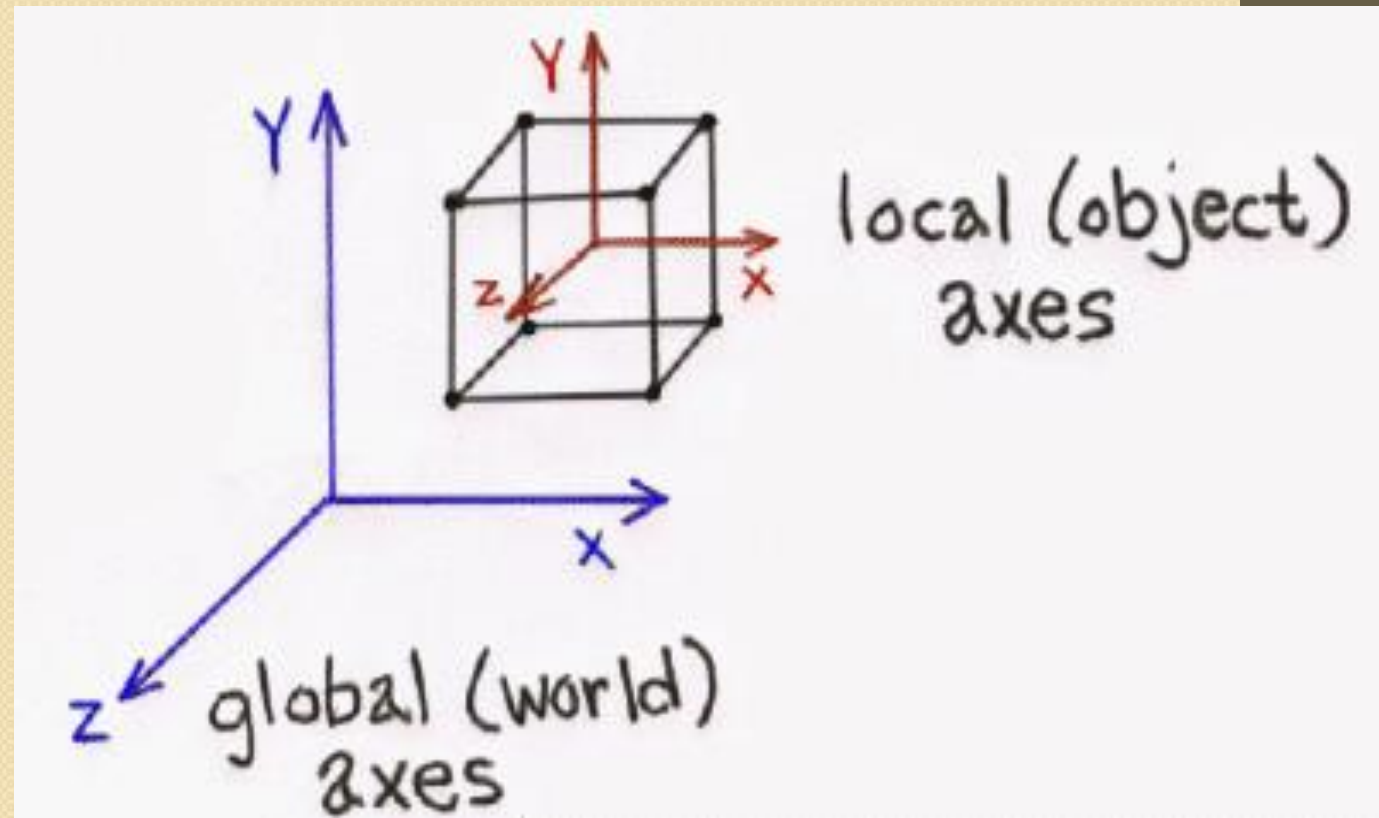

Shape function

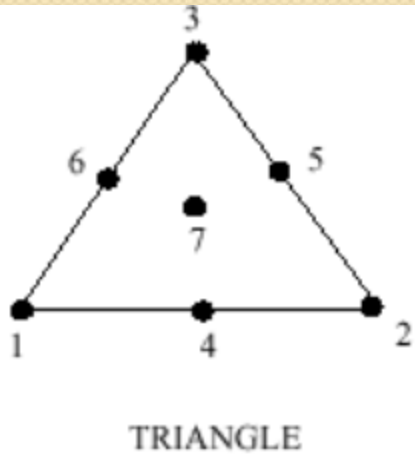

$$u_x = \begin{bmatrix} 1 - \frac{x}{l} & \frac{x}{l} \end{bmatrix} \begin{Bmatrix} u_{x_1} \\ u_{x_2} \end{Bmatrix}$$

$$\phi(x, y) = N_1(x, y) \phi_1 + N_2(x, y) \phi_2 + N_3(x, y) \phi_3$$

$$N_1 = a_1 + b_1x + c_1y$$

$$N_2 = a_2 + b_2x + c_2y$$

$$N_3 = a_3 + b_3x + c_3y$$

ϕ_1, ϕ_2, ϕ_3 = Field variables. N_1, N_2, N_3 = Shape functions.

Stiffness matrix

$P = [K] u$ 1 Dimensional FEA Equation

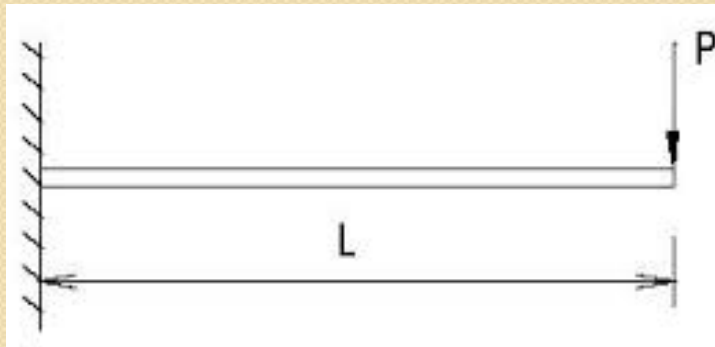

$$\begin{bmatrix} F_{1,1} \\ F_{2,1} \end{bmatrix} = \left(\frac{EA}{L} \right) \begin{bmatrix} 1 & -1 \\ -1 & 1 \end{bmatrix} \begin{bmatrix} u_1 \\ u_2 \end{bmatrix}$$

Constant Strain Triangle (CST)

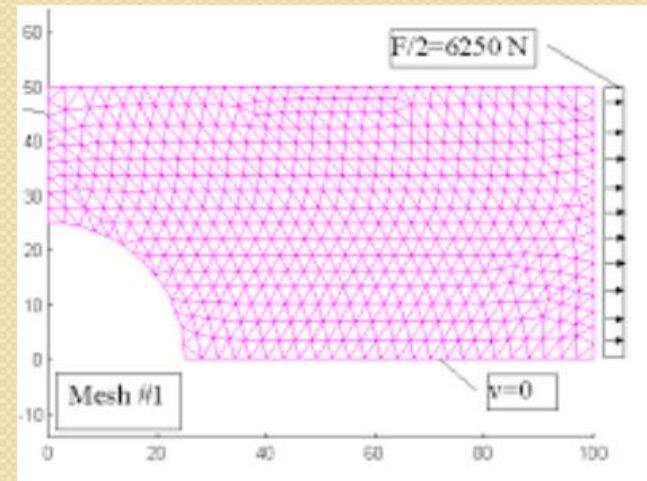
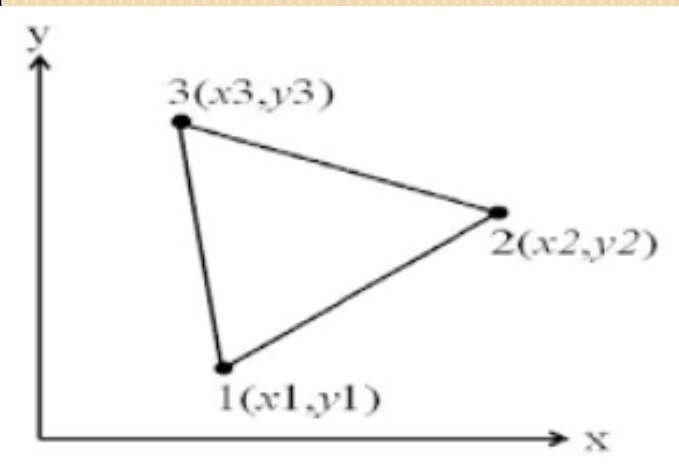

Merit: Calculation of stiffness matrix is easier.

Demerit: The strain variation within the element is considered as constant. So, the results will be poor.

Linear Strain Triangle (LST)

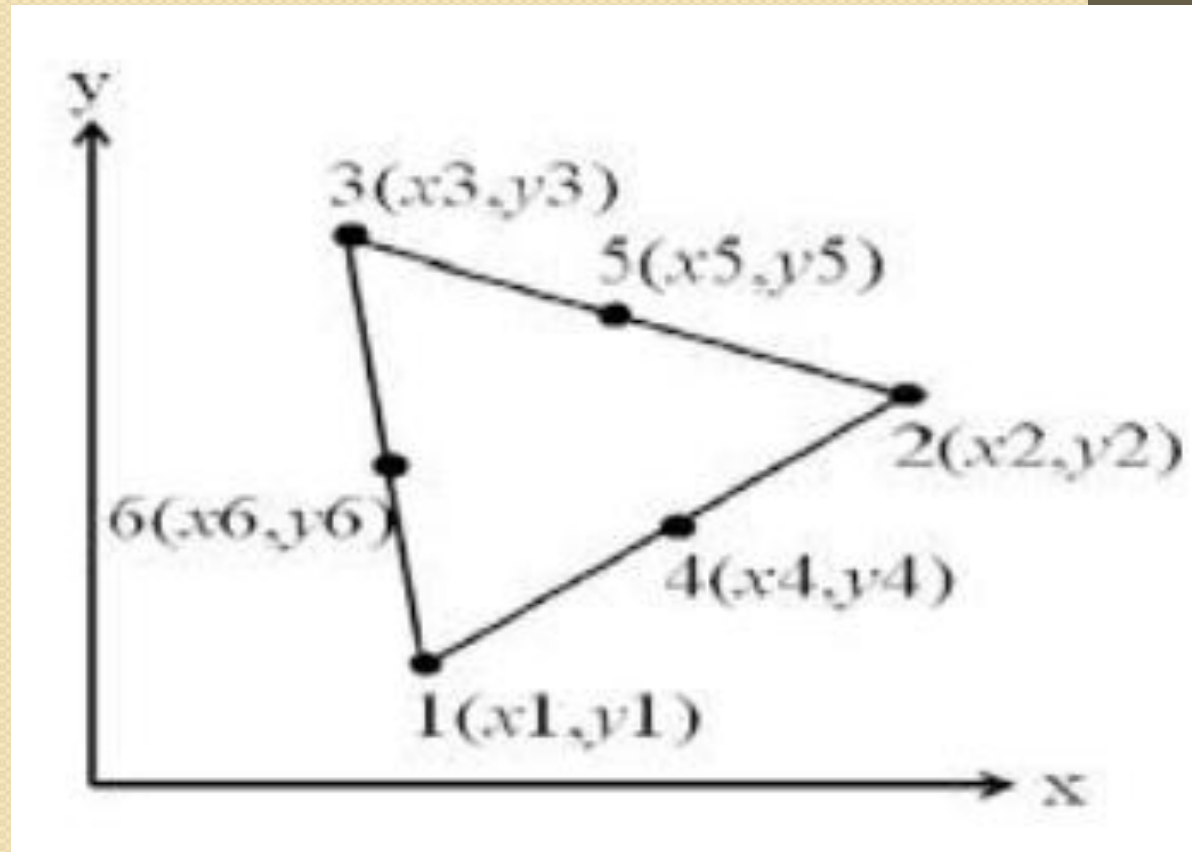

Quadratic Strain Triangle (QST),

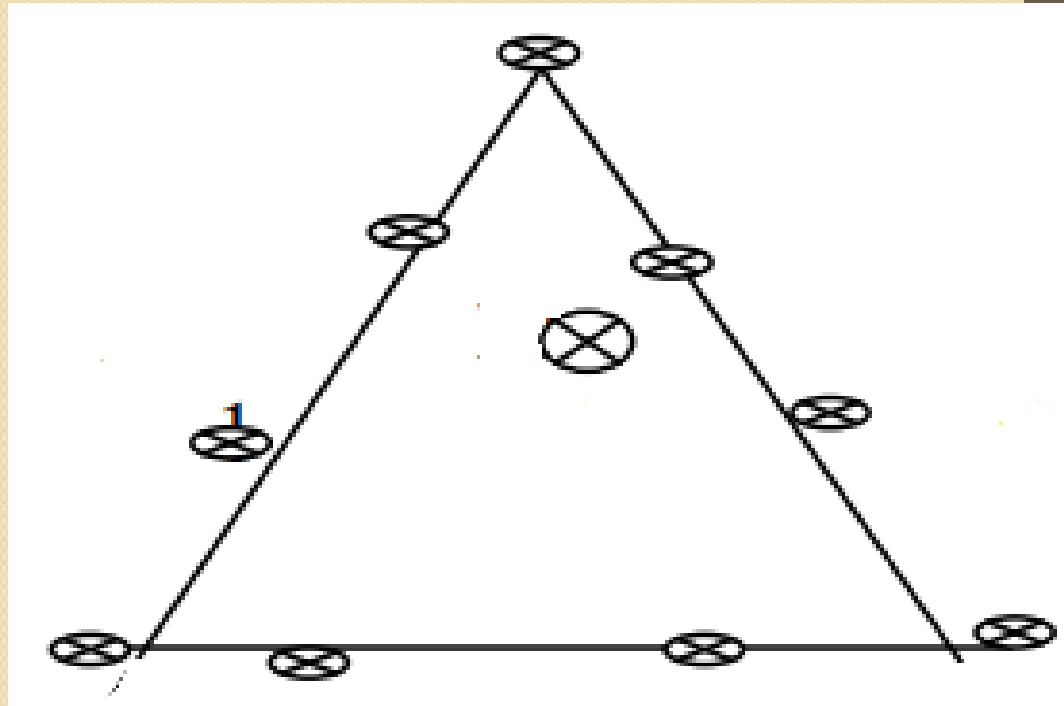

Plane stress and Plane strain

- **Plane stress**
 - One dimensional is too small when compared to other two dimensions.
- **Plane strain**
 - One dimensional is too large when compared to other two dimensions.

THANK YOU