



Knowledge Institute of Technology, Salem.
Department of Mechanical Engineering

Dynamics of Machinery

Presented by

S.Rajeshkanna, AP/Mech

What is a Governor??

A speed-sensitive device, designed to maintain a constant engine speed regardless of load variation.

The governor

- controlling the speed of an engine based on the load requirements.
- sense speed and sometimes load of a prime mover and adjust the energy source to maintain the desired level.

Purpose of governor

- To automatically maintain the uniform speed of the engine within the specified limits, whenever there is a variation of the load.
- To regulate the fuel supply to the engine as per load requirements.
- To regulate the mean speed of the engines.

Functions of Governor

- To provide the engine with the feedback mechanism to change speed as needed and to maintain a speed once reached.
- To control the engine speed by regulating the quantity of fuel as per the variation of load.
- When the load on an engine increases, its speed decreases, then the governor increases the supply of fuel & vice-versa in case of decrease of load.
- Governor has no control over the change in speed within the cycle and they are not able to store the energy as well.

Difference between flywheel and governor??

FLYWHEEL

- used because of variation of speed due to variation in the output torque of engine during a cycle.
- Limits the inertiabale fluctuation of speed during each cycle which arises due to fluctuation of turning moment on crank shaft.
- Stores excess of rotational energy from the power stroke and supply back during non- power strokes of the cycle.
- It controls the speed for one cycle only so it is continuous.

GOVERNOR

- used because of variation of speed due to variation in the load on the engine.
- Controls the mean speed of engine by varying the fuel supply which arises due to variation of load.
- When load on the engine increases, speed decreases, it increases the flow of fuel to keep the mean speed constant.
- It maintains constant mean speed over a period of time so it is discrete.

Inertia Governor :

- The obvious advantage of inertia governor lies in its rapid response to the effect of a change of load. This advantage is small, however by the practical difficulty of arranging for the complete balance of the revolving parts of the governor. For this reason Centrifugal governors are preferred over the inertia governors.

Centrifugal Governors

Types of Governor

1. **Centrifugal Governor-** The centrifugal governors are based on the balancing of centrifugal force on the rotating balls for an equal and opposite radial force, known as the controlling force. It consist of two fly balls of equal mass, which are attached to the arms.
2. **Inertia Governor-** In inertia governor the fly balls are arranged in such a manner that the angular acceleration or retardation of the governor shaft will change the position of these balls.

Inertia governors gives more rapid response to the effect of change of load but they are practically difficult to make because of partial balancing of the rotating parts of governors, therefore centrifugal governors are used widely.

Types of Centrifugal Governor

Centrifugal governor

Pendulum type

Watt governor

Loaded type

Dead weight governor

Spring controlled governor

Porter governor

Proell governor

Hartnell governor

Hartung governor

Wilson - Hartnel governor

Pickering governor

Working of Centrifugal Governor

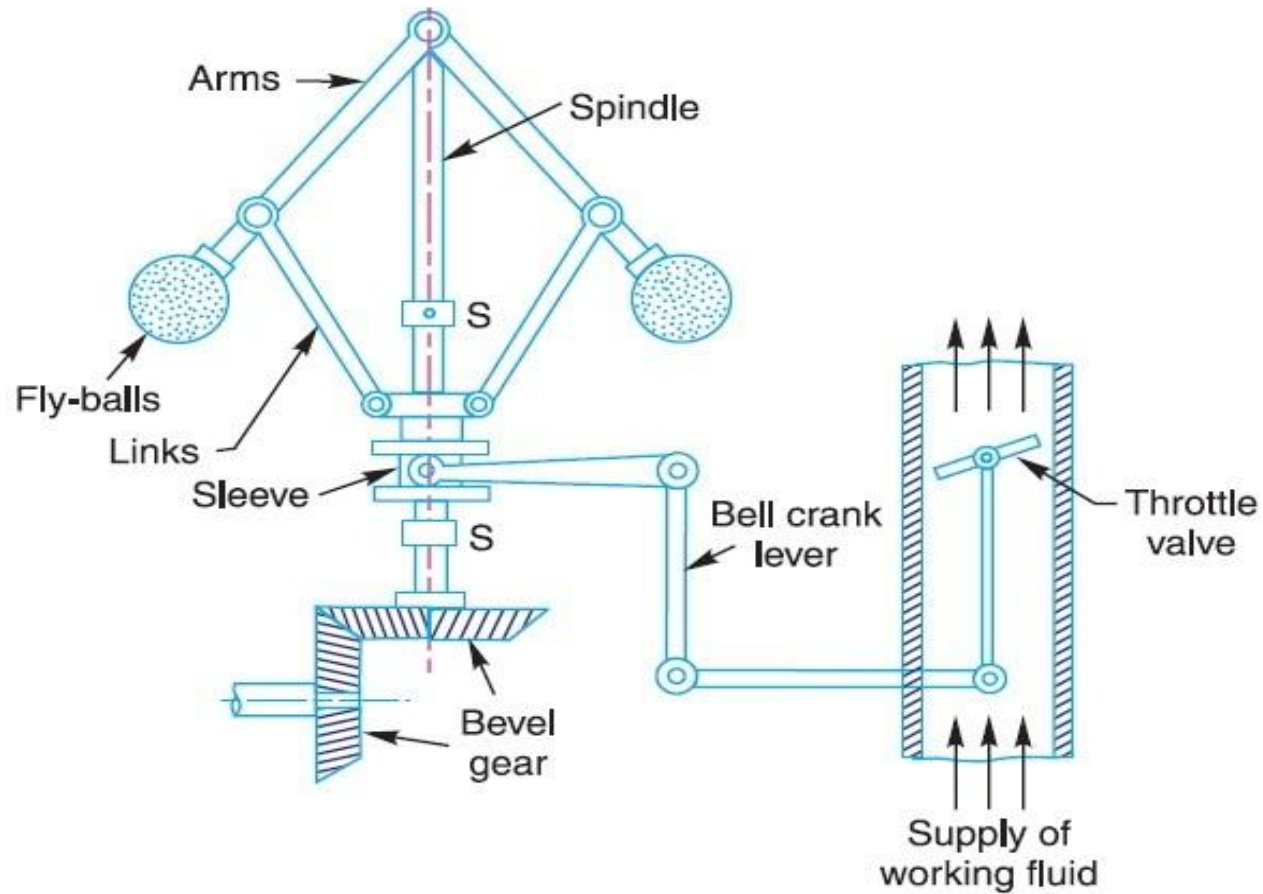

Centrifugal governor.

The downward movement of the sleeve operates a throttle to increase the supply of working fluid and thus the engine speed is increased.

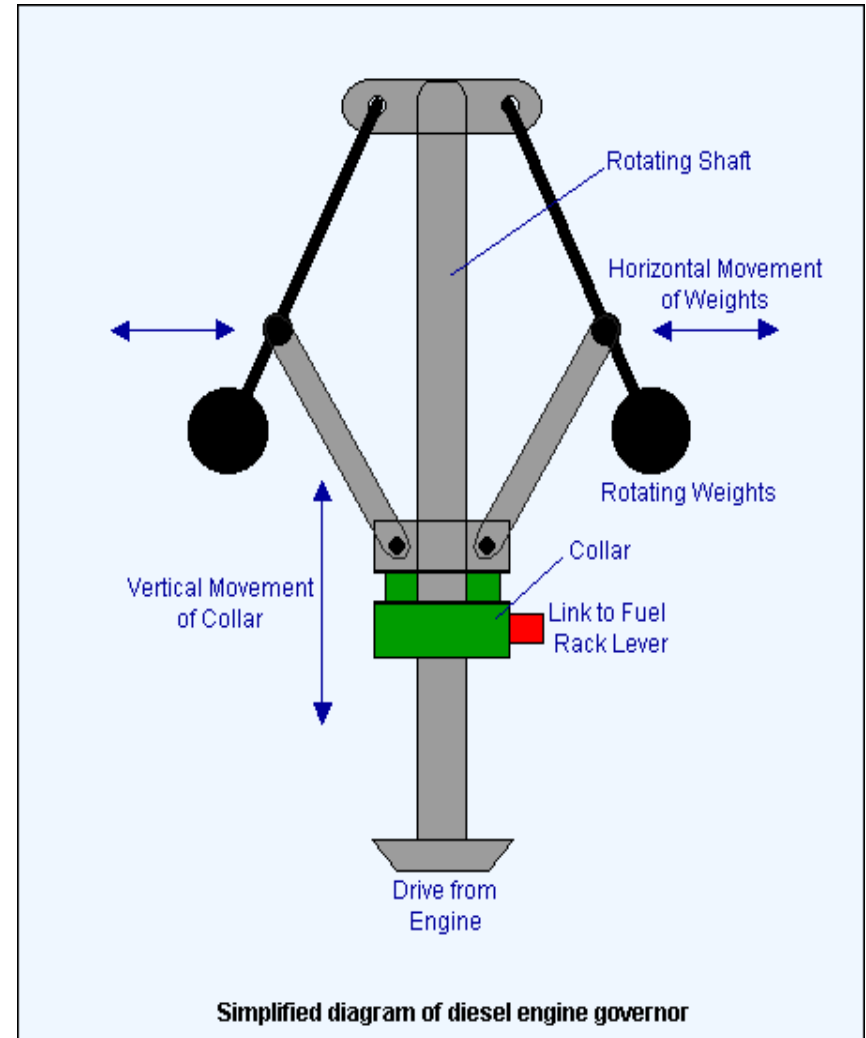
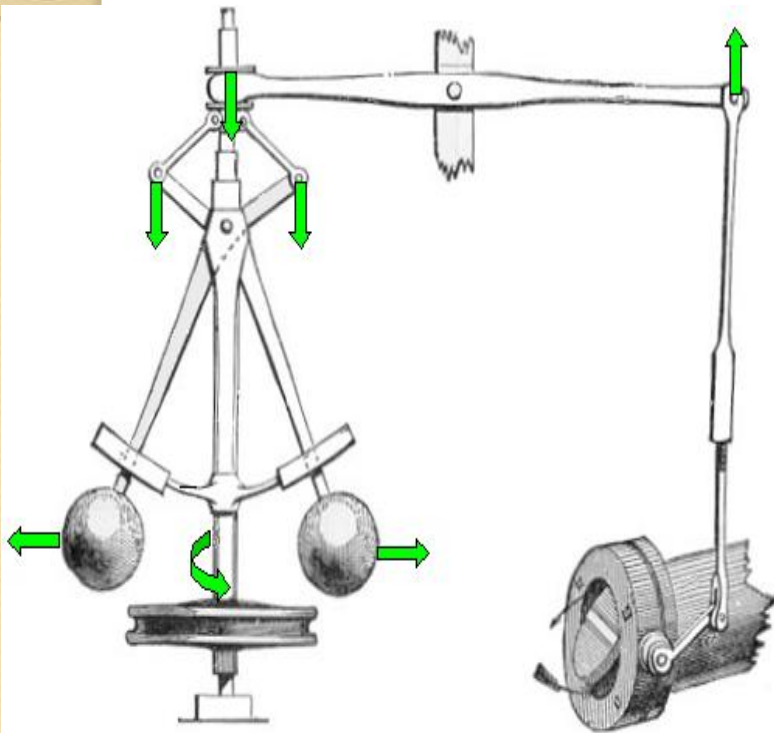

Terms used in Governor

1. **Height of a governor-** vertical distance from the centre of the ball to a point where the axes of the arms (or arms produced) intersect on the spindle axis. It is usually denoted by h .
2. **Equilibrium speed-** *speed at which the governor balls, arms etc., are in complete equilibrium and the sleeve does not tend to move upwards or downwards.*
3. **Mean equilibrium speed-** *speed at the mean position of the balls or the sleeve.*
4. **Maximum and minimum equilibrium speeds-** *The speeds at the maximum and minimum radius of rotation of the balls, without tending to move either way are known as maximum and minimum equilibrium speeds respectively.*
5. **Sleeve lift-** *It is the vertical distance which the sleeve travels due to change in equilibrium speed.*

There can be many equilibrium speeds between the mean and the maximum and the mean and the minimum equilibrium speeds.

Watt Governor

- It is the simplest form of centrifugal governor. It is basically a conical pendulum with links attached to a sleeve of negligible mass. The arms of governors may be connected to the spindle in following three ways;
- The pivot P , may be on the spindle axis
 - The pivot P , may be offset from spindle axis & the arms when produced intersect at O .
 - The pivot P , may be offset, at the arms crosses the axis at O .

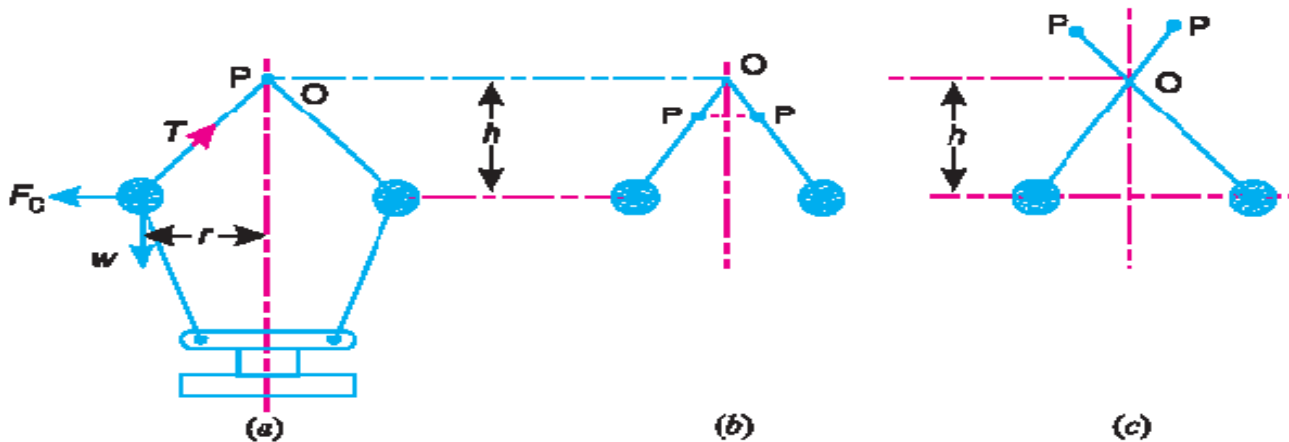

Let,

m = mass of the ball in Kg

w = weight of the ball in Newton = mg

T = tension in the arm in N

ω = angular velocity of arm and ball about the spindle axis in rad/sec

r = radius of rotation of ball in meter

F_c = centrifugal force acting on the balls in Newton ($m \omega^2 r$)

h = Height of governor in meter.

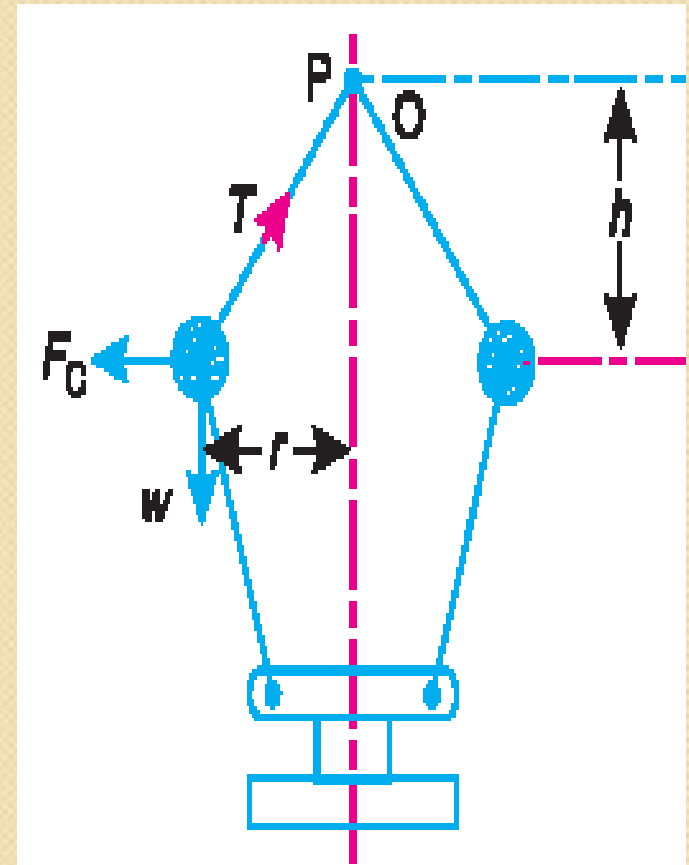

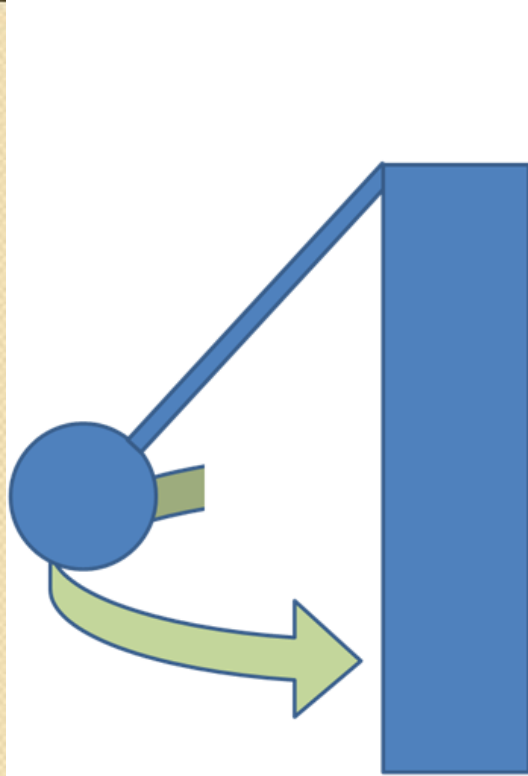

Reactive
Centrifugal

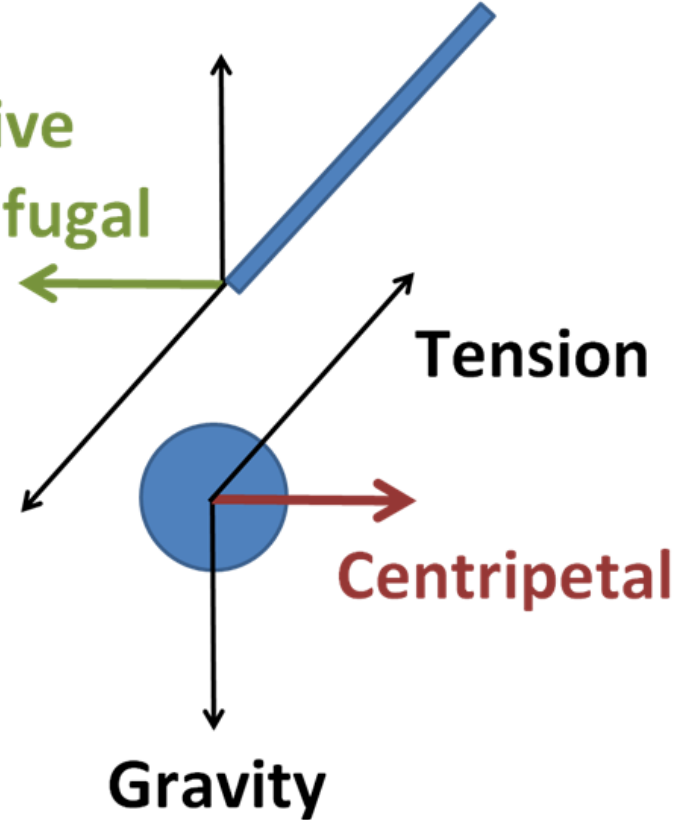

$$F_c \times h = W \times r$$

$$m r \omega^2 \times h = m \cdot g \cdot r$$

$$h = g / \omega^2$$

$$\omega = 2\pi N / 60$$

$$h = 9.81 / (2\pi N / 60)^2$$

$$h = 895 / N^2 \text{ meter}$$

By derivation we conclude that sleeve movement is very small for higher speed. As here sleeve is mass less, therefore it fails beyond 60 rpm.

m = mass of the ball in Kg

w = weight of the ball in Newton = mg

T = tension in the arm in N

ω = angular velocity of arm and ball about the spindle axis in rad/sec

r = radius of rotation of ball in meter

F_c = centrifugal force acting on the balls in Newton ($m \omega^2 r$)

h = Height of governor in meter.

T_1 = Force on the arm

T_2 = Force in the links

α = Angle of inclination of arm to vertical

β = Angle of inclination of link to vertical

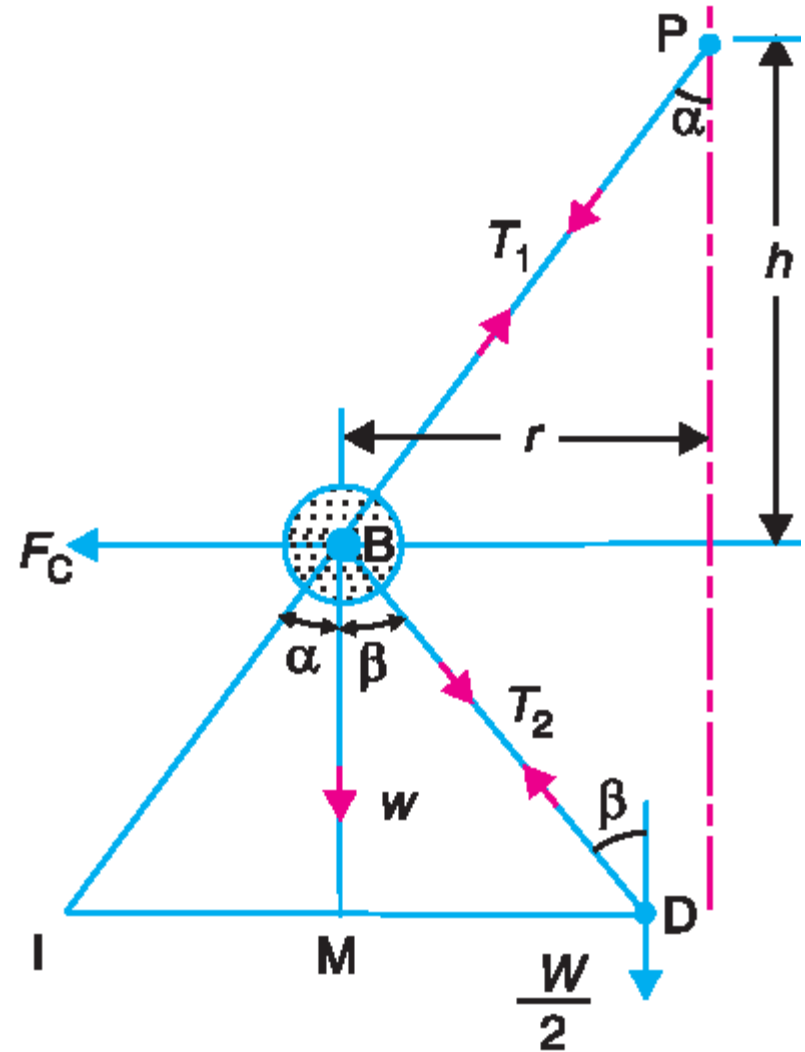

Final Equations:

$$1) \quad N^2 = \frac{(m + M)}{m} \times \frac{895}{h} \longrightarrow \text{Without Friction}$$

$$2) \quad N^2 = \frac{mg + (Mg \pm F)/2}{mg} \times (1+q) \times \frac{895}{h} \longrightarrow \text{With Friction}$$

$$3) \quad h = \frac{(m + M)}{m} \times \frac{g}{\omega^2}$$

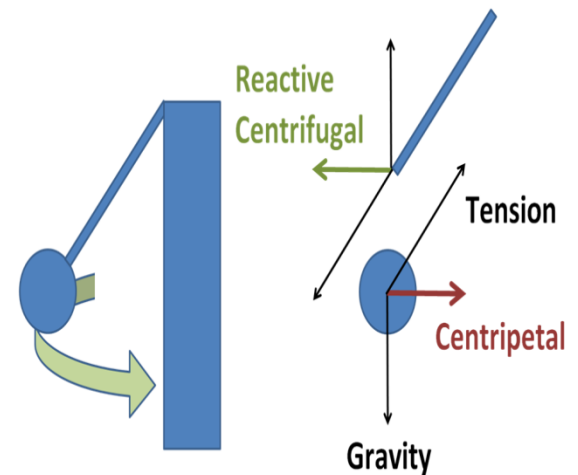

Proell Governor

The Proell governor has the balls fixed at B & C to the extension of the links DF & EG, as shown. The arms FP & GQ are pivoted at P & Q respectively.

Consider the equilibrium of the forces on one half of the governor. The instantaneous centre (I) lies on the intersection of the line PF produced and the line from the D drawn perpendicular to the spindle axis. The perpendicular BM is drawn on ID

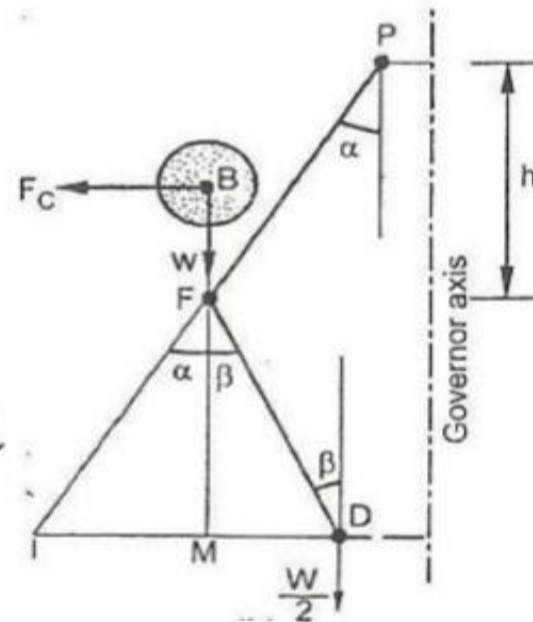
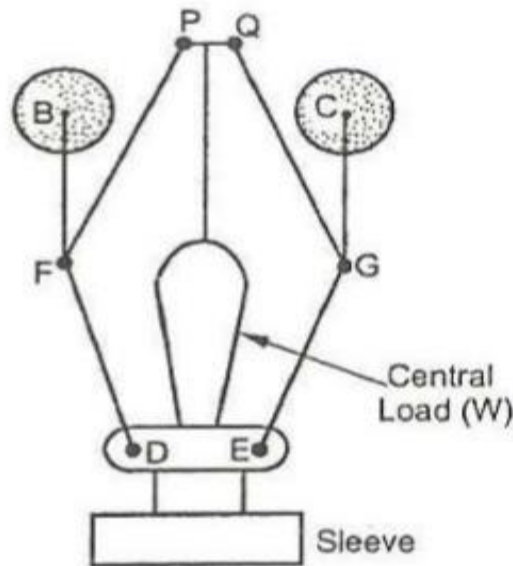

Final Equations-

$$1) \quad N^2 = \frac{FM}{BM} \left[\frac{(m + M)}{m} \right] \times \frac{895}{h} \quad \longrightarrow \quad \text{Since } h \text{ is in mtrs.}$$

- For the same effect in proell governor as obtained in porter governor, the mass required by fly ball is less as compared to that required in porter governor. Hence, overall inertia is reduced so, it is highly modified governor.*

Hartnell Governor

- It is a spring loaded governor, consists of two bell crank levers pivoted at the pts. O, O to the frame. Frame is attached to the governor spindle and therefore rotates with it. Each lever carries a ball at the end of the vertical arm OB & a roller at the end of horizontal arm OR. A helical spring in compression provides equal downward forces on two rollers through collar on the sleeve. The spring force may be adjusted by screwing a nut up or down on the sleeve.

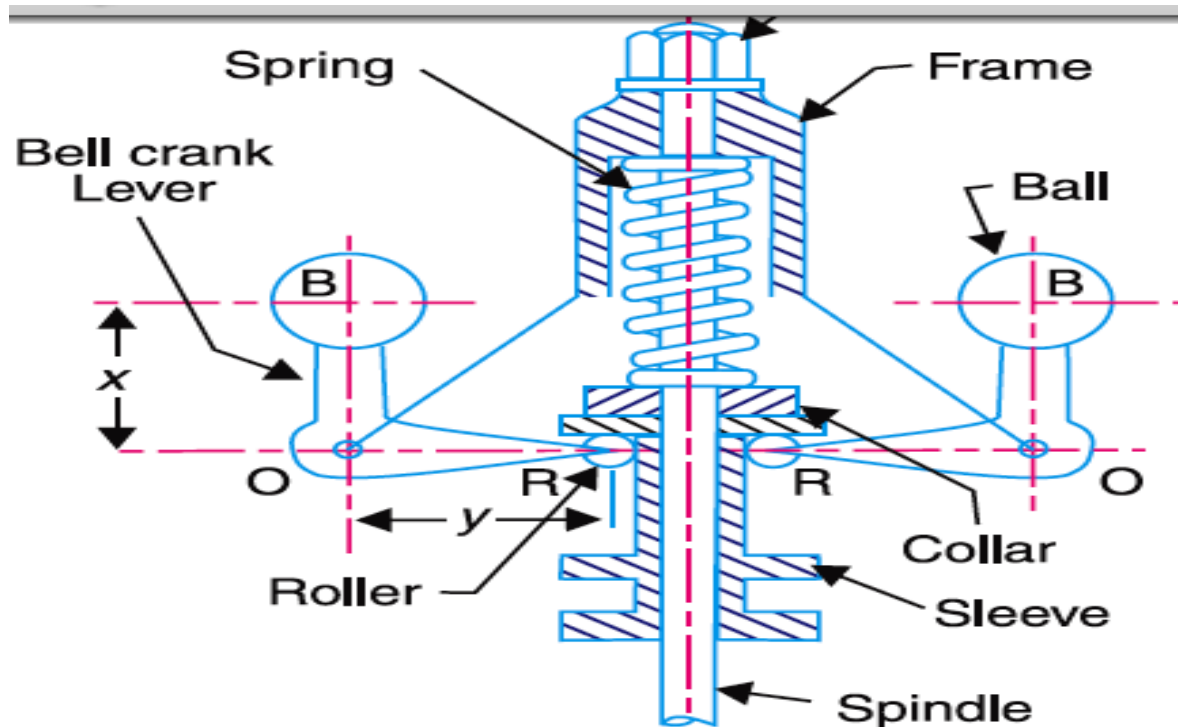

Fig. 18.18. Hartnell governor.

DERIVATION-

w=weight of fly ball

W=weight of sleeve(Dead weight)

S=force exerted on the sleeve by the spring that surrounds the spindle axis.

K=stiffness of spring

a,b=vertical & horizontal arm of bell crank.

R=radius of rotation.

Sum of moment about axis=0;

$$F \times a = W + S/2 \times b$$

$$W + S = 2F \times a/b$$

There are two cases,

a) Maximum speed

b) Minimum speed

- For Maximum speed,

$$W + S_1 = 2F_1 \times a/b \dots\dots\dots(1)$$

- For minimum speed

$$W + S_2 = 2F_2 \times a/b \dots\dots\dots(2)$$

- Subtracting equation (2) from (1)

$$S_1 - S_2 = 2(a/b) \times (F_1 - F_2)$$

- By Hock's Law

$$F = K \times x$$

$$S_1 - S_2 = K \times x$$

$$2(a/b)(F_1 - F_2) = K \times x \dots\dots\dots(3)$$

$$r_1 > r_2$$

$$\text{angle} = r_1 - r_2 / a \dots\dots\dots(4)$$

also

$$\text{angle} = x/b \dots\dots\dots(5)$$

- comparing equation (4) & (5)

$$x/b = r_1 - r_2 / a$$

$$x = (r_1 - r_2) \times b/a$$

- putting values in equation (3)

$$2(a/b) \times (F_1 - F_2) = K \times x$$

$$2(a/b) \times (F_1 - F_2) = K(r_1 - r_2/a) \times a$$

$$K = 2(a/b)^2 (F_1 - F_2 / r_1 - r_2)$$

Where K is the stiffness of the spring.

Characteristics of Governors

Different governors can be compared on the basis of following characteristics :

1. **Stability**-A governor is said to be stable when there is one radius of rotation of the balls for each speed which is within the speed range of the governor.
2. **Sensitiveness**- It is define as the extent of sleeve movement for a change in speed of the governor. According to this definition, the sensitiveness of the governor shall be determined by the ratio of speed range to the mean speed. The smaller the ratio more

$$\therefore \text{Sensitiveness} = \frac{N_2 - N_1}{N} = \frac{2(N_2 - N_1)}{(N_2 + N_1)}$$

where $N_2 - N_1$ = Speed range from no load to full load.

3. Isochronism -A governor is said to be isochronous if equilibrium speed is constant for all the radii of rotation in the working range. Therefore, for an isochronous governor the speed range is zero and this type of governor shall maintain constant speed.

4. Hunting- An excessively fast too and fro motion of the sleeve between the stopper due to resonance condition is known as hunting of governor.

Higher the sensitiveness of the governor, the problem of hunting becomes more acute.

$$\text{Stability} = 1/\text{Sensitivity}$$

- **Effort of Governor-** It is defined as the mean force acting on the sleeve to change its equilibrium position for fractional change in speed of governor.

$$\text{Mean torque on sleeve} = (0+E)/2 = E/2$$

- **Power of Governor-** Work done on sleeve to change its equilibrium position for fractional change in speed.

Controlling Force

- the inward radial **force** exerted on each ball of a centrifugal **governor** by the arms, spring, etc. which are attached to it. At any equilibrium speed the **controlling force** is equal and opposite to the centrifugal

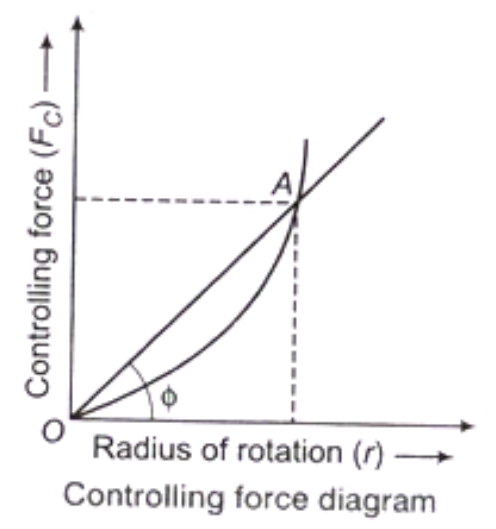

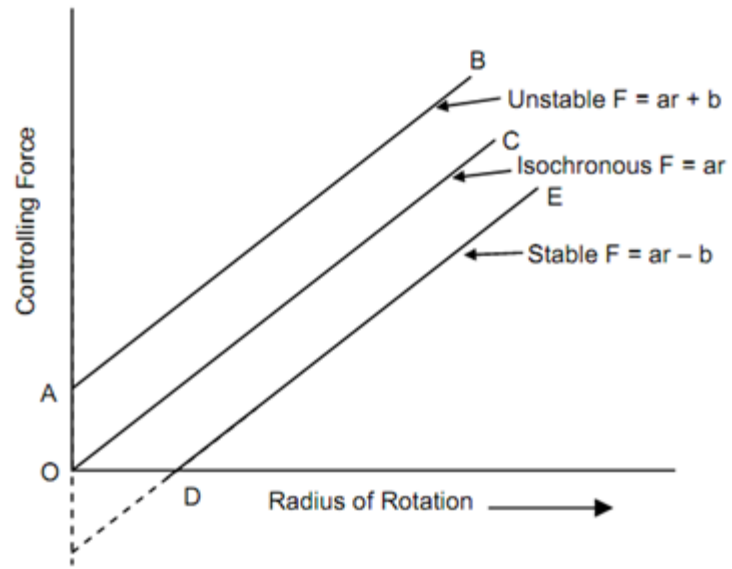

A gyroscope

- A **gyroscope** is a spinning wheel or disc in which the axis of rotation is free to assume any orientation by itself.

When viewing from rear or tail end

Turning direction	Engine rotation direction	Gyroscopic couple direction	Effect on plane
Left turn (-ve)	Anticlockwise (-ve)	$(-ve) \times (-ve) = (+ve)$ (Clockwise)	Dip the nose & raise the tail
Right turn (+ve)	Anticlockwise (-ve)	$(+ve) \times (-ve) = (-ve)$ (Anticlockwise)	Dip the tail & raise the nose
Left turn (-ve)	Clockwise (+ve)	$(-ve) \times (+ve) = (-ve)$ (Anticlockwise)	Dip the tail & raise the nose
Right turn (+ve)	Clockwise (+ve)	$(+ve) \times (+ve) = (+ve)$ (Clockwise)	Dip the nose & raise the tail

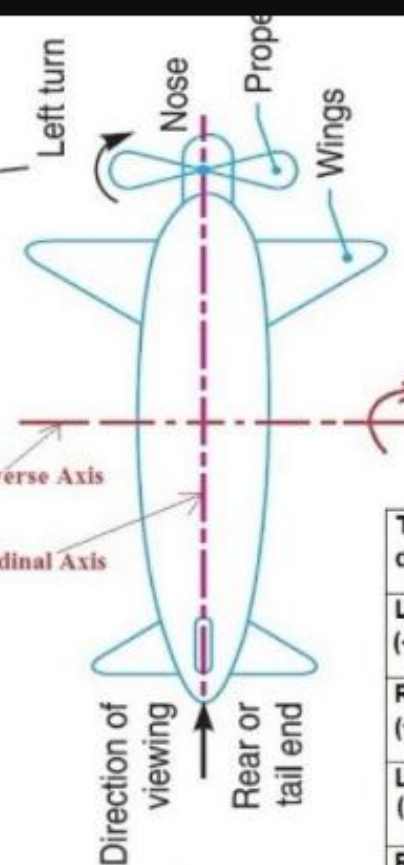

Fig-1 shows a top-down view of an aircraft with a dashed purple line representing the longitudinal axis and a dashed red line representing the transverse axis. The nose is at the top, and the rear or tail end is at the bottom. A gyroscope is shown at the tail end. Labels include 'Left turn', 'Nose', 'Propeller', 'Wings', 'Rear or tail end', 'Direction of viewing', and 'Gyroscopic couple'.

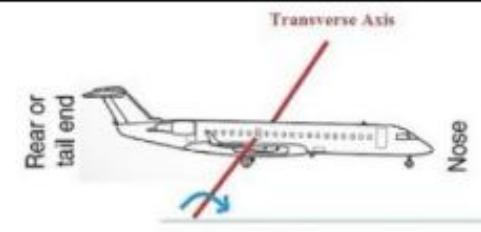

Fig-2 shows a side view of an aircraft with a red line representing the transverse axis passing through the center of gravity. Labels include 'Rear or tail end', 'Nose', and 'Transverse Axis'.

When viewing from rear or tail end

Turning direction	Engine rotation direction	Gyroscopic couple direction	Effect on plane
Left turn (-ve)	Anticlockwise (-ve)	$(-ve) \times (-ve) = (+ve)$ (Clockwise)	Dip the nose & raise the tail
Right turn (+ve)	Anticlockwise (-ve)	$(+ve) \times (-ve) = (-ve)$ (Anticlockwise)	Dip the tail & raise the nose
Left turn (-ve)	Clockwise (+ve)	$(-ve) \times (+ve) = (-ve)$ (Anticlockwise)	Dip the tail & raise the nose
Right turn (+ve)	Clockwise (+ve)	$(+ve) \times (+ve) = (+ve)$ (Clockwise)	Dip the nose & raise the tail